



**Wipers and Washers—Excursion, Super Duty Series F-250, F-350, F-450, F-550**

Refer to Wiring Diagrams Cell 59 ([F-Super Duty 250-550/Excursion, F-53 Motorhome Chassis](#)), Generic Electronic Module for schematic and connector information.

Refer to Wiring Diagrams Cell 81 ([F-Super Duty 250-550/Excursion, F-53 Motorhome Chassis](#)), Interval Wiper/Washer for schematic and connector information.

Refer to Wiring Diagrams Cell 82 ([F-Super Duty 250-550/Excursion, F-53 Motorhome Chassis](#)), Liftgate Wiper/Washer for schematic and connector information.

**Special Tool(s)**

	Alternator, Regulator, Battery and Starter Tester (ARBST) or equivalent 010-00736
	73III Automotive Meter 105-R0057 or equivalent
	Worldwide Diagnostic System (WDS) 418-F224, New Generation STAR (NGS) Tester 418-F052, or equivalent scan tool

**Principles of Operation—Excursion, Super Duty Series F-250, F-350, F-450, F-550**

The generic electronic module (GEM) receives inputs from the following:

- multifunction switch
- anti-lock brake control module (vehicle speed signal [VSS])
- ignition switch

The GEM uses these inputs to control the outputs to the following:

- windshield wiper high/low relay
- windshield wiper run/park relay
- windshield washer relay
- rear wiper motor relay
- rear window washer relay

**High Speed Windshield Wipers**

High speed is activated when the multifunction switch supplies ground resistance to the GEM windshield wiper inputs. The GEM then supplies ground to the windshield wiper run/park and high/low relay coils, activating the relays with voltage supplied from the ignition switch (RUN/ACCY) through the central junction box (CJB). When activated the windshield wiper run/park relay switches supply voltage to the windshield wiper high/low relay. The activated high/low relay then supplies voltage to the windshield wiper motor high speed input activating the wiper motor. Once the windshield wiper motor is activated, the run/park switch (internal to the wiper motor) switches a GEM input from ground to voltage. When the GEM receives voltage from the run/park switch, it removes ground from the run/park relay coil deactivating it. The windshield wiper motor continues to operate from voltage connected through the run/park switch and the windshield wiper run/park relay. When the windshield wiper motor returns to the park position, the internal run/park switch grounds the GEM input and the GEM removes ground from the windshield wiper high/low relay coil deactivating the high/low relay and windshield wiper motor. The GEM continues to cycle the windshield wipers until the inputs from the multifunction switch are changed from the high speed position.

**Low Speed Windshield Wipers**

Low speed is activated when the multifunction switch supplies a specific resistance value to the GEM windshield wiper speed inputs of the GEM. The GEM then supplies ground to only the windshield wiper run/park relay coil, activating it. When the windshield wiper run/park relay is activated, the deactivated windshield high/low relay connects voltage to the windshield wiper motor low input activating the wiper motor. The GEM continues to operate the windshield wiper motor in the same manner as in high speed, but in low speed with the wiper motor connected to the low speed input.

**Intermittent Speed Windshield Wipers**

The intermittent wiper speed is activated with specific resistance values controlled by the multifunction switch inputs to the GEM. The GEM then activates the windshield wiper run/park relay coil and switches voltage through the windshield wiper high/low relay. The high/low relay remains deactivated supplying the voltage to the wiper motor low speed input and activates the windshield wiper motor. When the windshield wiper motor returns to the park position, the internal run/park switch disconnects voltage to the wiper motor and connects to ground. This also grounds an input to the GEM. When the GEM receives the grounded input, it removes ground from the output to the windshield wiper run/park relay coil, deactivating it and disconnecting voltage to the wiper motor. The windshield wipers remain parked until the GEM completes a time-out and then repeats the intermittent windshield wiper cycle.

**Speed-Dependent Windshield Wipers**

The generic electronic module (GEM) responds to the windshield wiper control commands by interpreting inputs from the steering column multifunction switch. The speed dependent wipers will compensate for the extra moisture that accumulates on the windshield at higher speeds, except when the multifunction switch is in the INT 1 position. At higher speeds, the speed dependent feature shortens the delay between wipers when using the variable interval wipers. Delays will automatically adjust at speeds between 16 and 105 km/h (10 and 65 mph).

**Rear Intermittent Wiper System**

The rear window wiper intermittent speed is activated when the GEM receives specific resistance values controlled by the multifunction switch inputs to the GEM. The GEM then activates the rear wiper relay by momentarily grounding the relay coil. This activates the rear wiper motor by providing voltage from the battery junction box (BJB). Once the rear wiper motor is activated, its internal run/park switch connects voltage to the motor keeping it operating. When the windshield wiper motor returns to the park position, the run/park switch disconnects voltage internally from the wiper motor input reconnecting it to the GEM output. The rear window wiper remains parked until the GEM completes a time-out and then repeats the rear wiper cycle.

**Washer System**

The windshield washer or the rear window washer is activated by the GEM when it receives a specific resistance value from the multifunction switch between the washer inputs. Dependent on the correct input resistance, the GEM activates either the windshield washer or rear window washer relay by grounding the respective relay coil. When either relay is activated, it connects voltage to the washer pump while the deactivated relay provides ground to the washer pump. In this manner voltage polarity is reversible to achieve directional change of the washer pump and washer fluid.

**Inspection and Verification — Excursion, Super Duty Series F-250, F-350, F-450, F-550**

**NOTE:** Upon installation of a new generic electronic module (GEM), the module must be reconfigured. For additional information, refer to [Section 418-01](#).

1. Verify the customer concern by operating the system.
2. Visually inspect for the following obvious signs of mechanical or electrical damage.

**Visual Inspection Chart**

Mechanical	Electrical
<ul style="list-style-type: none"> <li>• Windshield washer hoses</li> <li>• Wiper linkage</li> <li>• Multifunction switch</li> </ul>	<ul style="list-style-type: none"> <li>• BJB Fuse 13 (10A)</li> <li>• BJB Fuse 1 (20A)</li> <li>• CJB Fuse 11 (30A)</li> <li>• Circuitry</li> <li>• Windshield wiper motor</li> </ul>

3. If an obvious cause for an observed or reported concern is found, correct the cause (if possible) before proceeding to the next step.
4. If the concern remains after the inspection, connect the scan tool to the data link connector (DLC) located beneath the instrument panel and select the vehicle to be tested from the scan tool menu. If the scan tool does not communicate with the vehicle:
  - check that the program card is correctly installed.
  - check the connections to the vehicle.
  - check the ignition switch position.
5. If the scan tool still does not communicate with the vehicle, refer to the scan tool manual.
6. Carry out the DATA LINK DIAGNOSTICS test. If the scan tool responds with:
  - CKT914, CKT915 or CKT70 = ALL ECUS NO RESP/NOT EQUIP, refer to [Section 418-00](#).
  - NO RESP/NOT EQUIP for GEM, go to Pinpoint Test A.
  - SYSTEM PASSED, retrieve and record the continuous diagnostic trouble codes (DTCs), erase the continuous DTCs and carry-out self-test diagnostics for the GEM.
7. If the DTCs retrieved are related to the concern, go to the GEM Diagnostic Trouble Code (DTC) Index.
8. If no DTCs related to the concern are retrieved, proceed to the Symptom Chart.

**GEM Diagnostic Trouble Code (DTC) Index**

DTC	Description	Source	Action
B1240	Wiper Washer Rear Pump Relay Circuit Failure	GEM	GO to <a href="#">Pinpoint Test K</a> .
B1241	Wiper Washer Rear Pump Relay Circuit Short to Battery	GEM	GO to <a href="#">Pinpoint Test K</a> .
B1342	ECU is Defective	GEM	CLEAR the DTCs. REPEAT the GEM self-test. If DTC B1342 is retrieved, INSTALL a new GEM. REFER to <a href="#">Section 419-10</a> .
B1431	Wiper Brake/Run Relay Circuit Failure	GEM	If the windshield wipers are inoperative, GO to <a href="#">Pinpoint Test B</a> . If the windshield wipers stay on continuously, GO to <a href="#">Pinpoint Test C</a> .
B1432	Wiper Brake/Run Relay Circuit Short to Battery	GEM	GO to <a href="#">Pinpoint Test B</a> .
B1434	Wiper Hi/Low Speed Relay Coil Circuit Failure	GEM	GO to <a href="#">Pinpoint Test D</a> .
B1436	Wiper Hi/Low Speed Relay Coil Circuit Short to Battery	GEM	GO to <a href="#">Pinpoint Test D</a> .
B1438	Wiper Mode Select Switch Circuit Failure	GEM	If the windshield wipers are inoperative, GO to <a href="#">Pinpoint Test B</a> . If both the windshield and rear window wipers are inoperative, GO to <a href="#">Pinpoint Test L</a> .
B1441	Wiper Mode Select Switch Circuit Short to Ground	GEM	GO to <a href="#">Pinpoint Test C</a> .
B1446	Wiper Park Sense Circuit Failure	GEM	If the intermittent windshield wiper speed does not operate correctly, GO to <a href="#">Pinpoint Test E</a> . If the speed dependent interval mode does not operate correctly, GO to <a href="#">Pinpoint Test G</a> . If both windshield and rear wipers are inoperative, GO to <a href="#">Pinpoint Test L</a> .
B1450	Wiper Wash/Delay Switch Circuit Failure	GEM	If the intermittent windshield wiper speed does not operate correctly, GO to <a href="#">Pinpoint Test E</a> . If the wash and wipe function does not operate correctly, GO to <a href="#">Pinpoint Test F</a> . If both the windshield and rear wipers are inoperative, GO to <a href="#">Pinpoint Test L</a> .
B1453	Wiper Wash/Delay Switch Circuit Short to Ground	GEM	If the windshield wipers stay on continuously, GO to <a href="#">Pinpoint Test C</a> . If the wash and wipe function does not operate correctly, GO to <a href="#">Pinpoint Test F</a> .
B1458	Wiper Washer Pump Motor Relay Circuit Failure	GEM	GO to <a href="#">Pinpoint Test F</a> .
B1460	Wiper Washer Pump Motor Relay Coil Circuit Short to Battery	GEM	GO to <a href="#">Pinpoint Test F</a> .
B1473	Wiper Low Speed Circuit Motor Failure	GEM	If the windshield wipers are inoperative, GO to <a href="#">Pinpoint Test B</a> . If the windshield wipers do not operate at high or low speed correctly, GO to <a href="#">Pinpoint Test D</a> . If the intermittent windshield wiper speed does not operate correctly, GO to <a href="#">Pinpoint Test E</a> .

B1475	Accessory Delay Relay Contact Short to Battery	GEM	REFER to <a href="#">Section 501-11</a> .
B1476	Wiper High Speed Circuit Motor Failure	GEM	If the windshield wipers are inoperative, GO to <a href="#">Pinpoint Test B</a> . If the windshield wipers do not operate at high or low speed correctly, GO to <a href="#">Pinpoint Test D</a> . If the intermittent windshield wiper does not operate correctly, GO to <a href="#">Pinpoint Test E</a> .
B1611	Rear Wiper Mode Switch Circuit Failure	GEM	GO to <a href="#">Pinpoint Test H</a> .
B1614	Rear Wiper Mode Switch Circuit Short to Ground	GEM	GO to <a href="#">Pinpoint Test I</a> .
B1820	Rear Wiper Motor Up Relay Circuit Short to Battery +	GEM	GO to <a href="#">Pinpoint Test H</a> .
B1839	Rear Wiper Motor Circuit Failure	GEM	GO to <a href="#">Pinpoint Test H</a> .
—	All other DTCs.	GEM	REFER to <a href="#">Section 419-10</a>

**Symptom Chart — Excursion, Super Duty Series F-250, F-350, F-450, F-550**

**Symptom Chart**





Condition	Possible Sources	Action
<ul style="list-style-type: none"> <li>No communication with the generic electronic module (GEM)/central timer module (CTM)</li> </ul>	<ul style="list-style-type: none"> <li>GEM/CTM.</li> <li>Central junction box (CJB).</li> <li>CJB Fuse 15 (5A).</li> <li>Circuitry.</li> </ul>	<ul style="list-style-type: none"> <li>GO to <a href="#">Pinpoint Test A</a>.</li> </ul>
<ul style="list-style-type: none"> <li>The windshield wipers are inoperative</li> </ul>	<ul style="list-style-type: none"> <li>Windshield wiper run/park relay.</li> <li>Windshield wiper high/low relay.</li> <li>multifunction switch.</li> <li>Circuitry.</li> <li>Ignition switch.</li> <li>Windshield wiper motor.</li> <li>Generic electronic module (GEM).</li> </ul>	<ul style="list-style-type: none"> <li>GO to <a href="#">Pinpoint Test B</a>.</li> </ul>
<ul style="list-style-type: none"> <li>The windshield wipers stay on continuously</li> </ul>	<ul style="list-style-type: none"> <li>Windshield wiper run/park relay.</li> <li>Windshield wiper high/low relay.</li> <li>Multifunction switch.</li> <li>Circuitry.</li> <li>Windshield wiper motor.</li> <li>Generic electronic module (GEM).</li> </ul>	<ul style="list-style-type: none"> <li>GO to <a href="#">Pinpoint Test C</a>.</li> </ul>
<ul style="list-style-type: none"> <li>The high/low windshield wiper speeds do not operate correctly</li> </ul>	<ul style="list-style-type: none"> <li>Windshield wiper high/low relay.</li> <li>Multifunction switch.</li> <li>Circuitry.</li> <li>Windshield wiper motor.</li> <li>Generic electronic module (GEM).</li> </ul>	<ul style="list-style-type: none"> <li>GO to <a href="#">Pinpoint Test D</a>.</li> </ul>
<ul style="list-style-type: none"> <li>The intermittent windshield wiper speed does not operate correctly</li> </ul>	<ul style="list-style-type: none"> <li>Windshield wiper run/park relay.</li> <li>Multifunction switch.</li> <li>Circuitry.</li> <li>Windshield wiper motor.</li> <li>Generic electronic module (GEM).</li> </ul>	<ul style="list-style-type: none"> <li>GO to <a href="#">Pinpoint Test E</a>.</li> </ul>
<ul style="list-style-type: none"> <li>The windshield wiper wash and wipe function does not operate</li> </ul>	<ul style="list-style-type: none"> <li>Windshield washer relay.</li> <li>Rear window washer relay.</li> <li>Multifunction switch.</li> <li>Circuitry.</li> <li>Washer pump.</li> <li>Generic electronic module (GEM).</li> </ul>	<ul style="list-style-type: none"> <li>GO to <a href="#">Pinpoint Test F</a>.</li> </ul>
<ul style="list-style-type: none"> <li>The windshield wiper speed dependent interval mode does not operate correctly</li> </ul>	<ul style="list-style-type: none"> <li>Central junction box (CJB).</li> <li>Generic electronic module (GEM).</li> <li>Circuitry.</li> <li>ABS module.</li> </ul>	<ul style="list-style-type: none"> <li>GO to <a href="#">Pinpoint Test G</a>.</li> </ul>
<ul style="list-style-type: none"> <li>The rear window wiper is inoperative</li> </ul>	<ul style="list-style-type: none"> <li>Battery junction box (BJB) Fuse 1 (20A).</li> <li>Rear window wiper relay.</li> <li>Multifunction switch.</li> <li>Circuitry.</li> <li>Ignition switch.</li> <li>BJB.</li> <li>Rear window wiper motor.</li> <li>Generic electronic module (GEM).</li> </ul>	<ul style="list-style-type: none"> <li>GO to <a href="#">Pinpoint Test H</a>.</li> </ul>
<ul style="list-style-type: none"> <li>The rear window wiper stays on continuously</li> </ul>	<ul style="list-style-type: none"> <li>Rear window wiper relay.</li> <li>Multifunction switch.</li> <li>Circuitry.</li> <li>Rear window wiper motor.</li> <li>Generic electronic module (GEM).</li> </ul>	<ul style="list-style-type: none"> <li>GO to <a href="#">Pinpoint Test I</a>.</li> </ul>
<ul style="list-style-type: none"> <li>The rear window intermittent wiper speed does not operate correctly</li> </ul>	<ul style="list-style-type: none"> <li>Multifunction switch.</li> <li>Circuitry.</li> <li>Generic electronic module (GEM).</li> </ul>	<ul style="list-style-type: none"> <li>GO to <a href="#">Pinpoint Test J</a>.</li> </ul>
<ul style="list-style-type: none"> <li>The rear window wash and wipe function does not operate</li> </ul>	<ul style="list-style-type: none"> <li>Rear window wiper relay.</li> <li>Multifunction switch.</li> <li>Circuitry.</li> <li>Washer pump.</li> <li>Generic electronic module (GEM).</li> </ul>	<ul style="list-style-type: none"> <li>GO to <a href="#">Pinpoint Test K</a>.</li> </ul>
<ul style="list-style-type: none"> <li>The wipers are inoperative—both windshield and rear window</li> </ul>	<ul style="list-style-type: none"> <li>Central junction box (CJB) fuse 11 (30A).</li> <li>CJB.</li> <li>Windshield wiper run/park relay.</li> <li>Windshield wiper high/low relay.</li> <li>Windshield washer relay.</li> <li>Rear window wiper relay.</li> <li>Rear window washer relay.</li> <li>Multifunction switch.</li> <li>Circuitry.</li> <li>Washer pump.</li> <li>Generic electronic module (GEM).</li> </ul>	<ul style="list-style-type: none"> <li>GO to <a href="#">Pinpoint Test L</a>.</li> </ul>
<ul style="list-style-type: none"> <li>The wash and wipe function does not operate—both windshield and rear window</li> </ul>	<ul style="list-style-type: none"> <li>Battery junction box (BJB) Fuse 13</li> </ul>	<ul style="list-style-type: none"> <li>GO to <a href="#">Pinpoint Test</a></li> </ul>

	(10A). <ul style="list-style-type: none"> <li>• Windshield washer relay.</li> <li>• Rear window washer relay.</li> <li>• Multifunction switch.</li> <li>• Circuitry.</li> <li>• Washer pump.</li> <li>• BJB.</li> <li>• Generic electronic module (GEM).</li> </ul>	<a href="#">M.</a>
--	---	--------------------

**Pinpoint Tests — Excursion, Super Duty Series F-250, F-350, F-450, F-550**



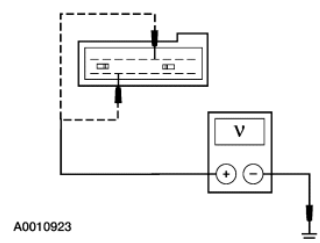

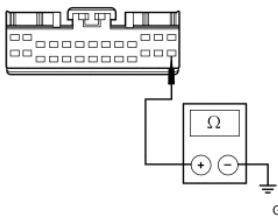
**NOTE:** When installing a new generic electronic module (GEM), the module must be configured. Refer to Section 418-01 Module Configuration.

**PINPOINT TEST A: NO COMMUNICATION WITH THE GENERIC ELECTRONIC MODULE (GEM)/CENTRAL TIMER MODULE (CTM)**

CONDITIONS	DETAILS/RESULTS/ACTIONS
<p><b>A1 CHECK CENTRAL JUNCTION BOX (CJB) FOR OPENS</b></p>	
<p>1 </p> <p>2 </p> <p style="text-align: center;">GEM/CTM C240d</p> <p>3 </p>	<p>3 Measure the voltage between CJB C240d, terminal 4, and ground; and between CJB C240d, terminal 16, and ground.</p> <ul style="list-style-type: none"> <li>• <b>Is the voltage greater than 10 volts?</b></li> </ul> <p>→ <b>Yes</b> GO to <a href="#">A2</a>.</p> <p>→ <b>No</b> INSTALL a new CJB. TEST the system for normal operation.</p>
<p><b>A2 CHECK CIRCUIT 676 (PK/OG) FOR OPEN</b></p>	
<p>1 </p> <p style="text-align: center;">GEM/CTM C240a</p> <p>2 </p>	<p>2 Measure the resistance between GEM/CTM C240a pin 26, circuit 676 (PK/OG), and ground.</p> <ul style="list-style-type: none"> <li>• <b>Is the resistance less than 5 ohms?</b></li> </ul> <p>→ <b>Yes</b> REFER to <a href="#">Section 418-00</a>.</p> <p>→ <b>No</b> REPAIR the circuit. TEST the system for normal operation.</p>

**PINPOINT TEST B: THE WINDSHIELD WIPERS ARE INOPERATIVE**

CONDITIONS	DETAILS/RESULTS/ACTIONS
<p><b>B1 CHECK THE REAR WINDOW WIPER OPERATION</b></p>	

<p>1</p> 	<p>2 Activate the rear window wiper ON and OFF.</p> <ul style="list-style-type: none"> <li>• Does the rear window wiper operate correctly?</li> </ul> <p>→ Yes GO to <a href="#">B2</a>.</p> <p>→ No GO to <a href="#">Pinpoint Test L</a>.</p>																								
<p><b>B2 RETRIEVE RECORDED GEM DIAGNOSTIC TROUBLE CODES (DTCs)</b></p>																									
	<p>1 Using the recorded results from the generic electronic module (GEM) front wiper self-test.</p> <ul style="list-style-type: none"> <li>• Are any DTCs recorded?</li> </ul> <p>→ Yes If DTC B1431 and windshield wipers are inoperative, GO to <a href="#">B4</a> . If DTC B1432, B1458, B1840, B1473, and B1476 are recorded together, GO to <a href="#">B4</a> . If DTC B1438, GO to <a href="#">B5</a> . If DTC B1446, GO to <a href="#">Pinpoint Test L</a> . If DTCs B1473, and B1476 are recorded and the wipers operate in high speed only, or in low speed only, GO to <a href="#">Pinpoint Test D</a> .</p> <p>→ No GO to <a href="#">B3</a> .</p>																								
<p><b>B3 MONITOR THE GEM PIDs WPMODE, WPHISP, AND WPRUN</b></p>																									
<p>1</p> 	<p>2 Monitor GEM PIDs WPMODE, WPHISP, and WPRUN while selecting each of the windshield wiper multifunction switch positions and depressing the windshield washer switch.</p> <table border="1" data-bbox="630 1010 914 1178"> <thead> <tr> <th></th> <th>WPHISP</th> <th>WPRUN</th> <th>WPMOD</th> </tr> </thead> <tbody> <tr> <td>INTER-</td> <td>OFF</td> <td>ON</td> <td>INTV 1-7</td> </tr> <tr> <td>MITTENT</td> <td></td> <td></td> <td></td> </tr> <tr> <td>LOW</td> <td>OFF</td> <td>ON</td> <td>LOW</td> </tr> <tr> <td>HIGH</td> <td>ON</td> <td>ON</td> <td>HIGH</td> </tr> <tr> <td>WASH</td> <td></td> <td></td> <td>WASH</td> </tr> </tbody> </table> <ul style="list-style-type: none"> <li>• Do the GEM PID values agree with the multifunction switch positions?</li> </ul> <p>→ Yes GO to <a href="#">B4</a> .</p> <p>→ No GO to <a href="#">B5</a> .</p>		WPHISP	WPRUN	WPMOD	INTER-	OFF	ON	INTV 1-7	MITTENT				LOW	OFF	ON	LOW	HIGH	ON	ON	HIGH	WASH			WASH
	WPHISP	WPRUN	WPMOD																						
INTER-	OFF	ON	INTV 1-7																						
MITTENT																									
LOW	OFF	ON	LOW																						
HIGH	ON	ON	HIGH																						
WASH			WASH																						
<p><b>B4 CHECK THE WINDSHIELD WIPER MOTOR OPERATION</b></p>																									
<p>1</p> 	<p>2 Select the GEM active command WASH RLY. Trigger WASH RLY to the ON and OFF positions.</p> <ul style="list-style-type: none"> <li>• Does the windshield wiper motor activate and deactivate correctly when WASH RLY is triggered ON and OFF?</li> </ul> <p>→ Yes GO to <a href="#">B16</a> .</p> <p>→ No GO to <a href="#">B7</a> .</p>																								
<p><b>B5 CHECK THE MULTIFUNCTION SWITCH</b></p>																									
<p>1</p> 	<p>2 Disconnect multifunction switch C230a and C230b.</p> <p>3 Carry out the multifunction switch component test. Refer to the Wiring Diagram Manual Cell 149.</p> <ul style="list-style-type: none"> <li>• Did the multifunction switch pass the component test?</li> </ul>																								

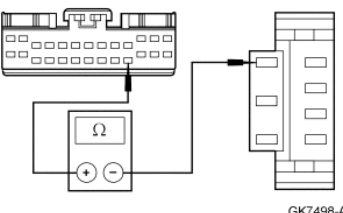
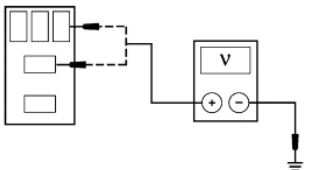
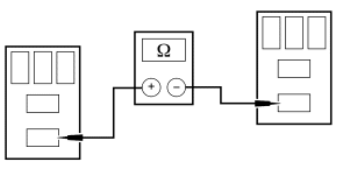
	<p>→ <b>Yes</b> GO to <a href="#">B6</a>.</p> <p>→ <b>No</b> INSTALL a new multifunction switch. REFER to <a href="#">Section 211-05</a>. CLEAR the DTCs. REPEAT the self-test.</p>
<p><b>B6 CHECK CIRCUIT 684 (PK/YE) FOR AN OPEN</b></p>	
<p>1 </p> <p>GEM C240a</p> <p>2 </p> <p>GK7498-A</p>	<p>2 Measure the resistance between multifunction switch C230a pin 589, circuit 684 (PK/YE), harness side and GEM C240a pin 23, circuit 684 (PK/YE), harness side.</p> <ul style="list-style-type: none"> <li>• Is the resistance less than 5 ohms?</li> </ul> <p>→ <b>Yes</b> GO to <a href="#">B16</a>.</p> <p>→ <b>No</b> REPAIR the circuit. CLEAR the DTCs. REPEAT the self-test.</p>
<p><b>B7 CHECK CIRCUIT 297 (BK/LG) FOR AN OPEN</b></p>	
<p>2 </p> <p>A0010037</p>	<p>1 Disconnect the windshield wiper run/park relay.</p> <p>2 Measure the voltage between windshield wiper run/park relay connector pin 1, circuit 297 (BK/LG), harness side and ground; and between windshield wiper run/park relay connector pin 5, circuit 950 (WH/BK), harness side and ground.</p> <ul style="list-style-type: none"> <li>• Are the voltages greater than 10 volts?</li> </ul> <p>→ <b>Yes</b> GO to <a href="#">B8</a>.</p> <p>→ <b>No</b> REPAIR the circuit. CLEAR the DTCs. REPEAT the self-test.</p>
<p><b>B8 CHECK CIRCUIT 63 (RD) FOR AN OPEN</b></p>	
<p>2 </p> <p>GK3412-A</p>	<p>1 Disconnect the windshield wiper high/low relay.</p> <p>2 Measure the resistance between windshield wiper run/park relay connector pin 3, circuit 63 (RD), harness side and windshield wiper high/low relay connector pin 3, circuit 63 (RD), harness side.</p> <ul style="list-style-type: none"> <li>• Is the resistance less than 5 ohms?</li> </ul> <p>→ <b>Yes</b> GO to <a href="#">B9</a>.</p> <p>→ <b>No</b> REPAIR the circuit. CLEAR the DTCs. REPEAT the self-test.</p>
<p><b>B9 CHECK THE WINDSHIELD WIPER RUN/PARK AND HIGH/LOW RELAYS</b></p>	
	<p>1 Carry out the relay component test on the windshield wiper run/park and high/low relays. Refer to the Wiring Diagram Manual Cell 149.</p>

• Did both relays pass the component test?

→ Yes  
GO to [B10](#).

→ No  
INSTALL a new relay. CLEAR the DTCs. REPEAT the self-test.

**B10 CHECK THE WINDSHIELD WIPER MOTOR OPERATION FROM THE HI/LO RELAY**

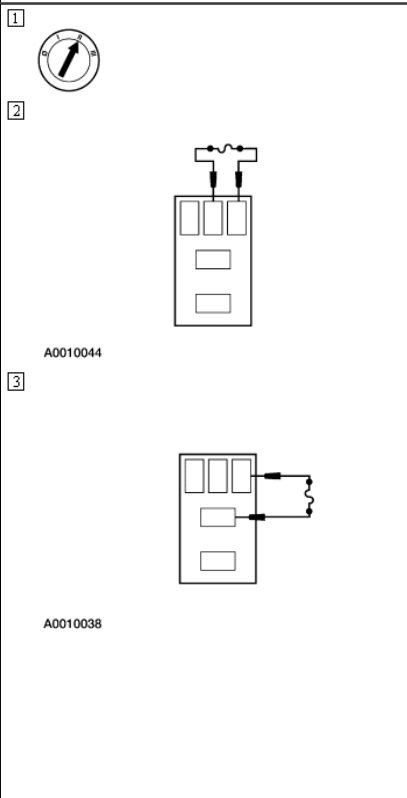

2 Using a fused jumper wire, jumper windshield wiper high/low relay pin 1, circuit 297 (BK/LG), harness side and pin 4, circuit 58 (WH), harness side.

3 Using a fused jumper wire, jumper windshield wiper high/low relay pin 1, circuit 297 (BK/LG), harness side and pin 5, circuit 56 (DB/OG).

• Does the wiper motor operate?

→ Yes  
GO to [B11](#).

→ No  
GO to [B13](#).

**B11 CHECK CIRCUIT 646 (YE/WH) FOR A SHORT TO VOLTAGE**

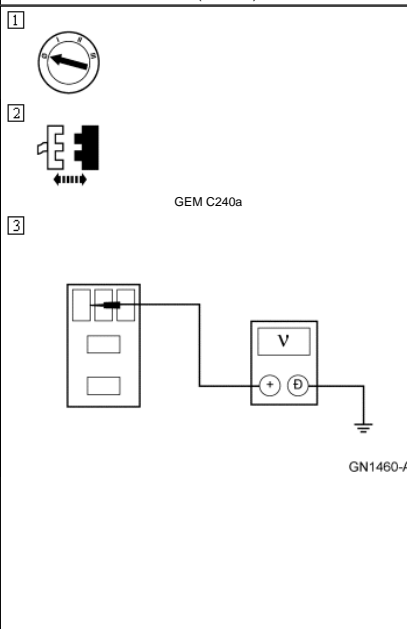

3 Measure the voltage between windshield wiper run/park relay connector pin 2, circuit 646 (YE/WH), and ground.

• Is voltage present?

→ Yes  
REPAIR the circuit. CLEAR the DTCs. REPEAT the self-test.

→ No  
GO to [B12](#).

**B12 CHECK CIRCUIT 646 (YE/WH) FOR AN OPEN**

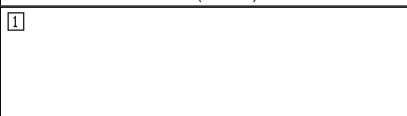

1 Measure the resistance between GEM C240a pin 3, circuit 646 (YE/WH), harness side and windshield wiper run/park relay connector pin 2, circuit 646 (YE/WH), harness side.

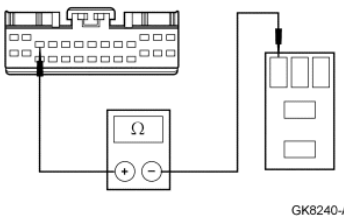

GK8240-A

- Is the resistance less than 5 ohms?

→ **Yes**  
GO to [B16](#).

→ **No**  
REPAIR the circuit. CLEAR the DTCs. REPEAT the self-test.

**B13 CHECK CIRCUITS 56 (DB/OG) AND 58 (WH) FOR AN OPEN**

1 

Windshield Wiper Motor C151

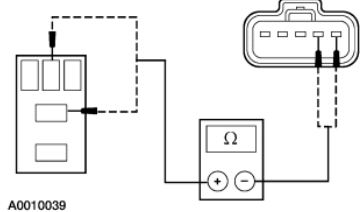
2 

A0010039

2 Measure the resistance between windshield wiper motor C151 pin 1, circuit 56 (DB/O), harness side and windshield wiper high/low relay connector pin 5, circuit 56 (DB/OG), harness side; and between windshield wiper motor C151 pin 2, circuit 58 (WH), harness side and windshield wiper high/low relay connector pin 4, circuit 58 (WH), harness side.

- Are the resistances less than 5 ohms?

→ **Yes**  
GO to [B14](#).

→ **No**  
REPAIR the circuit in question. CLEAR the DTCs. REPEAT the self-test.

**B14 CHECK CIRCUIT 57 (BK) FOR AN OPEN**

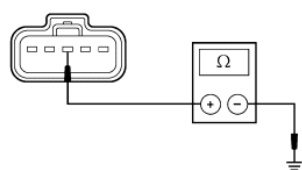
1 

A0010040

1 Measure the resistance between windshield wiper motor C151 pin 3, circuit 57 (BK), harness side and ground.

- Is the resistance less than 5 ohms?

→ **Yes**  
GO to [B15](#).

→ **No**  
REPAIR the circuit. CLEAR the DTCs. REPEAT the self-test.

**B15 CHECK THE WINDSHIELD WIPER MOTOR**

1 Carry out the windshield wiper motor component test as outlined in this Section.

- Does the wiper motor pass the component test?

→ **Yes**  
The concern may be intermittent. RECONNECT the connectors. CLEAR the DTCs. TEST the system for normal operation. VERIFY the concern.





→ **No**  
INSTALL a new windshield wiper motor. REFER to [Windshield Wiper Motor](#) in this Section. CLEAR the DTCs. REPEAT the self-test.





**B16 CHECK FOR CORRECT GEM OPERATION**

1 Disconnect all GEM connectors.

	<p>2 Check:</p> <ul style="list-style-type: none"> <li>• for corrosion</li> <li>• for pushed-out pins</li> </ul> <p>3 Connect all GEM connectors and make sure they seat correctly.</p> <p>4 Operate the system and verify the concern is still present.</p> <ul style="list-style-type: none"> <li>• <b>Is the concern still present?</b></li> </ul> <p>→ <b>Yes</b> INSTALL a new GEM. REFER to <a href="#">Section 419-10</a>. CLEAR the DTCs. REPEAT the self-test.</p> <p>→ <b>No</b> The system is operating correctly at this time. Concern may have been caused by a loose or corroded connector. CLEAR the DTCs. REPEAT the self-test.</p>
--	---

**PINPOINT TEST C: THE WINDSHIELD WIPERS STAY ON CONTINUOUSLY**

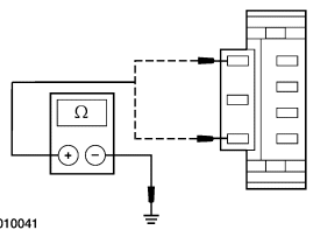

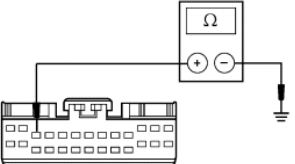
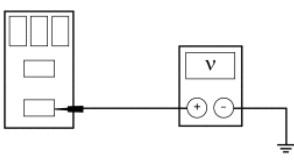
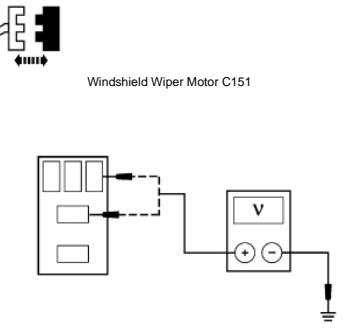

CONDITIONS	DETAILS/RESULTS/ACTIONS
<b>C1 CHECK THE REAR WINDOW WIPER OPERATION</b>	
<p>1 </p>	<p>2 Activate the rear window wiper on and off.</p> <ul style="list-style-type: none"> <li>• <b>Does the rear window wiper operate correctly?</b></li> </ul> <p>→ <b>Yes</b> GO to <a href="#">C2</a>.</p> <p>→ <b>No</b> GO to <a href="#">Pinpoint Test L</a>.</p>
<b>C2 RETRIEVE THE RECORDED GENERIC ELECTRONIC MODULE (GEM) DIAGNOSTIC TROUBLE CODES (DTCs)</b>	
	<p>1 Using the recorded results from the GEM front wiper self-test:</p> <ul style="list-style-type: none"> <li>• <b>Are any DTCs retrieved?</b></li> </ul> <p>→ <b>Yes</b> If DTC B1431, GO to <a href="#">C4</a> . If DTC B1441, GO to <a href="#">C5</a> . If DTC B1453, GO to <a href="#">C5</a> .</p> <p>→ <b>No</b> GO to <a href="#">C3</a>.</p>
<b>C3 MONITOR THE GEM PIDs WPMODE AND WASH_SW</b>	
<p>1 </p> <p>2 </p>	<p>2 Monitor GEM PIDs WPMODE and WASH_SW while selecting each of the windshield wiper multifunction switch positions and depressing the windshield washer switch.</p> <ul style="list-style-type: none"> <li>• <b>Do the GEM PID values agree with the multifunction switch positions?</b></li> </ul> <p>→ <b>Yes</b> GO to <a href="#">C4</a>.</p> <p>→ <b>No</b> GO to <a href="#">C5</a>.</p>
<b>C4 CHECK THE WINDSHIELD WIPER MOTOR OPERATION USING GEM ACTIVE COMMAND WIPER RLY</b>	
<p>1 </p> <p>2 </p>	<p>2 Select GEM active command WIPER RLY. Trigger WIPER RLY to the ON and OFF positions.</p> <ul style="list-style-type: none"> <li>• <b>Does the windshield wiper motor activate and deactivate correctly when WIPER RLY is triggered ON and OFF?</b></li> </ul> <p>→ <b>Yes</b> GO to <a href="#">C13</a>.</p>



	<p>→ <b>No</b> GO to <a href="#">C7</a>.</p>
<p><b>C5 CHECK THE MULTIFUNCTION SWITCH</b></p>	
<p>1</p> 	<p>2 Disconnect multifunction switch C230a and C230b. 3 Carry out the multifunction switch component test. Refer to the Wiring Diagram Manual Cell 149.</p> <ul style="list-style-type: none"> <li>• <b>Did the multifunction switch pass the component test?</b></li> </ul> <p>→ <b>Yes</b> GO to <a href="#">C6</a>.</p> <p>→ <b>No</b> INSTALL a new multifunction switch. REFER to <a href="#">Section 211-05</a>. CLEAR the DTCs. REPEAT the self-test.</p>
<p><b>C6 CHECK CIRCUITS 680 (LB/OG) AND 684 (PK/YE) FOR A SHORT TO GROUND</b></p>	
<p>1</p>  <p>GEM C240a</p> <p>2</p>  <p>A0010041</p>	<p>2 Measure the resistance between multifunction switch C230a pin 590, circuit 680 (LB/OG), harness and ground; and between multifunction switch C230a pin 589, circuit 684 (PK/YE), harness and ground.</p> <ul style="list-style-type: none"> <li>• <b>Are the resistances greater than 10,000 ohms?</b></li> </ul> <p>→ <b>Yes</b> GO to <a href="#">C13</a>.</p> <p>→ <b>No</b> REPAIR the circuit in question. CLEAR the DTCs. REPEAT the self-test.</p>
<p><b>C7 ISOLATE SHORT TO GROUND AT THE WINDSHIELD WIPER RUN/PARK RELAY</b></p>	
	<p>1 Disconnect the windshield wiper run/park relay.</p> <ul style="list-style-type: none"> <li>• <b>Do the wipers stop operating?</b></li> </ul> <p>→ <b>Yes</b> GO to <a href="#">C8</a>.</p> <p>→ <b>No</b> GO to <a href="#">C10</a>.</p>
<p><b>C8 CHECK THE WINDSHIELD WIPER RUN/PARK RELAY</b></p>	
<p>1</p> 	<p>2 Disconnect the windshield wiper run/park relay. 3 Carry out the component test on the windshield wiper run/park relay. Refer to the Wiring Diagram Manual, cell 149.</p> <ul style="list-style-type: none"> <li>• <b>Did the windshield wiper run/park relay pass the component test?</b></li> </ul> <p>→ <b>Yes</b> GO to <a href="#">C9</a>.</p> <p>→ <b>No</b> INSTALL a new windshield wiper run/park relay. CLEAR the DTCs. REPEAT the self-test.</p>
<p><b>C9 CHECK CIRCUIT 646 (YE/WH) FOR A SHORT TO GROUND</b></p>	
<p>1</p>  <p>GEM C240a</p> <p>2</p>	<p>2 Measure the resistance between GEM C240a pin 3, circuit 646 (YE/WH), harness side and ground.</p>

 <p>A0010042</p>	<ul style="list-style-type: none"> <li>• Is the resistance greater than 10,000 ohms?</li> </ul> <p>→ <b>Yes</b> GO to <a href="#">C13</a>.</p> <p>→ <b>No</b> REPAIR the circuit. CLEAR the DTCs. REPEAT the self-test.</p>
<p><b>C10 ISOLATE SHORT TO GROUND AT THE WINDSHIELD WIPER HIGH/LOW RELAY</b></p>	
	<p>1 Disconnect the windshield wiper high/low relay.</p> <ul style="list-style-type: none"> <li>• Do the wipers stop operating?</li> </ul> <p>→ <b>Yes</b> GO to <a href="#">C11</a>.</p> <p>→ <b>No</b> GO to <a href="#">C12</a>.</p>
<p><b>C11 CHECK CIRCUIT 63 (RD) FOR A SHORT TO VOLTAGE</b></p>	
<p>1</p>  <p>GN1456-A</p>	<p>1 Measure the voltage between windshield wiper high/low relay connector pin 3, circuit 63 (RD), harness side and ground.</p> <ul style="list-style-type: none"> <li>• Is the voltage greater than 10 volts?</li> </ul> <p>→ <b>Yes</b> REPAIR the circuit. CLEAR the DTCs. REPEAT the self-test.</p> <p>→ <b>No</b> INSTALL a new windshield wiper high/low relay. CLEAR the DTCs. REPEAT the self-test.</p>
<p><b>C12 CHECK CIRCUITS 56 (DB/OG) AND 58 (WH) FOR A SHORT TO VOLTAGE</b></p>	
<p>1</p>  <p>Windshield Wiper Motor C151</p> <p>A0010037</p>	<p>2 Measure the voltage between windshield wiper high/low relay connector pin 5, circuit 56 (DB/OG), harness side and ground; and between windshield wiper high/low relay connector pin 4, circuit 58 (WH), harness side and ground.</p> <ul style="list-style-type: none"> <li>• Are the voltages greater than 10 volts?</li> </ul> <p>→ <b>Yes</b> REPAIR the circuit in question. CLEAR the DTCs. REPEAT the self-test.</p> <p>→ <b>No</b> REFER to Windshield Wiper Component Test in this section. CLEAR the DTCs. REPEAT the self-test.</p>
<p><b>C13 CHECK FOR CORRECT GEM OPERATION</b></p>	
	<p>1 Disconnect all GEM connectors.</p> <p>2 Check:</p>

	<ul style="list-style-type: none"> <li>• for corrosion</li> <li>• for pushed out pins</li> </ul> <p>3 Connect all GEM connectors and make sure they seat correctly.</p> <p>4 Operate the system and verify the concern is still present.</p> <ul style="list-style-type: none"> <li>• <b>Is the concern still present?</b></li> </ul> <p>→ <b>Yes</b> INSTALL a new GEM. REFER to <a href="#">Section 419-10</a>. CLEAR the DTCs. REPEAT the self-test.</p> <p>→ <b>No</b> The system is operating correctly at this time. Concern may have been caused by a loose or corroded connector. CLEAR the DTCs. REPEAT the self-test.</p>
--	---

**PINPOINT TEST D: THE HIGH/LO WINDSHIELD WIPER SPEEDS DO NOT OPERATE CORRECTLY**

CONDITIONS	DETAILS/RESULTS/ACTIONS
<b>D1 RETRIEVE THE RECORDED GENERIC ELECTRONIC MODULE (GEM) DIAGNOSTIC TROUBLE CODES (DTCs)</b>	
	<p>1 Using the recorded results from the GEM front wiper self-test:</p> <ul style="list-style-type: none"> <li>• <b>Are any DTCs recorded?</b></li> </ul> <p>→ <b>Yes</b> If DTC B1434, GO to <a href="#">D5</a> . If DTC B1436, GO to <a href="#">D6</a> . If DTC B1473, GO to <a href="#">D6</a> . If DTC B1476, GO to <a href="#">D6</a> .</p> <p>→ <b>No</b> GO to <a href="#">D2</a>.</p>
<b>D2 MONITOR THE GEM PIDs WPMODE AND WASH_SW</b>	
<p>1 </p> <p>2 </p>	<p>3 Monitor GEM PIDs WPMODE and WASH_SW while selecting each of the windshield wiper multifunction switch positions and depressing the windshield washer switch.</p> <ul style="list-style-type: none"> <li>• <b>Do the GEM PID values agree with the multifunction switch positions?</b></li> </ul> <p>→ <b>Yes</b> GO to <a href="#">D3</a>.</p> <p>→ <b>No</b> GO to <a href="#">D4</a>.</p>
<b>D3 CHECK THE WINDSHIELD WIPER MOTOR OPERATION USING ACTIVE COMMANDS WIPER RLY AND SPEED RLY</b>	
<p>1 </p>	<p>1 Select GEM active command WIPER RLY and SPEED RLY. Trigger WIPER RLY and SPEED RLY to the ON and OFF positions.</p> <ul style="list-style-type: none"> <li>• <b>Does the windshield wiper motor operate in the low and high speeds when WIPER RLY and SPEED RLY are triggered to ON and OFF?</b></li> </ul> <p>→ <b>Yes</b> GO to <a href="#">D13</a>.</p> <p>→ <b>No</b> GO to <a href="#">D5</a>.</p>
<b>D4 CHECK THE MULTIFUNCTION SWITCH</b>	
<p>1 </p>	<p>2 Disconnect multifunction switch C230a and C230b.</p> <p>3 Carry out the multifunction switch component test. Refer to the Wiring Diagram Manual, cell 149.</p> <ul style="list-style-type: none"> <li>• <b>Did the multifunction switch pass the component test?</b></li> </ul> <p>→ <b>Yes</b> GO to <a href="#">D13</a>.</p> <p>→ <b>No</b></p>

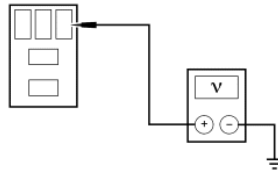
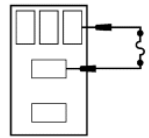
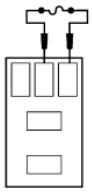
INSTALL a new multifunction switch. REFER to <a href="#">Section 211-05</a> . CLEAR the DTCs. REPEAT the self-test.	
<b>D5 CHECK CIRCUIT 297 (BK/LG) FOR AN OPEN</b>	
<p>1  Windshield Wiper High/Low Relay</p> <p>2 </p> <p>3 </p> <p style="text-align: right;">GK3408-A</p>	<p>3 Measure the voltage between windshield wiper high/low relay pin 1, circuit 297 (BK/LG), and ground.</p> <ul style="list-style-type: none"> <li>• Is the voltage greater than 10 volts?</li> </ul> <p>→ Yes GO to <a href="#">D6</a>.</p> <p>→ No REPAIR the circuit. CLEAR the DTCs. REPEAT the self-test.</p>
<b>D6 CHECK THE WINDSHIELD WIPER HIGH/LOW RELAY</b>	
	<p>1 Carry out the relay component test on the windshield wiper high/low relay. Refer to the Wiring Diagram Manual Cell 149.</p> <ul style="list-style-type: none"> <li>• Did the windshield wiper high/low relay pass the component test?</li> </ul> <p>→ Yes GO to <a href="#">D7</a>.</p> <p>→ No INSTALL a new windshield wiper high/low relay. CLEAR the DTCs. REPEAT the self-test.</p>
<b>D7 CHECK THE WINDSHIELD WIPER MOTOR OPERATION</b>	
<p>1 </p> <p>A0010038</p> <p>2 </p> <p>A0010044</p>	<p>1 Connect a fused jumper wire between windshield wiper high/low relay connector pin 1, circuit 297 (BK/LG), harness side and pin 5, circuit 56 (DB/OG), harness side.</p> <p>2 Connect a fused jumper wire between windshield wiper high/low relay connector pin 1, circuit 297 (BK/LG), harness side and pin 4, circuit 58 (WH)</p> <ul style="list-style-type: none"> <li>• Does the wiper motor operate at low and high speeds when the relay pins are jumpered?</li> </ul> <p>→ Yes GO to <a href="#">D10</a>.</p> <p>→ No GO to <a href="#">D8</a>.</p>
<b>D8 CHECK CIRCUITS 56 (DB/OG) AND 58 (WH) FOR AN OPEN</b>	
<p>1</p>	

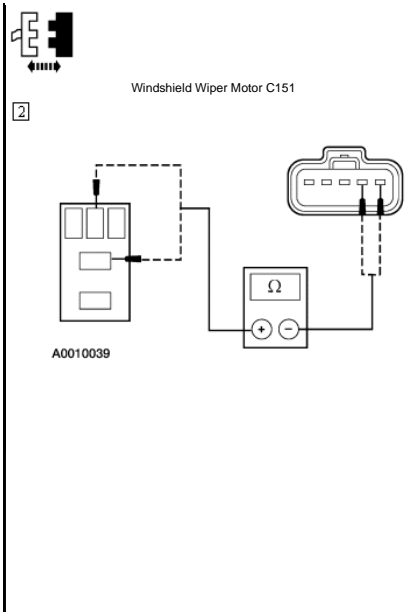

3 Measure the resistance between windshield wiper high/low relay connector pin 5, circuit 56 (DB/OG), harness side and windshield wiper motor C151 pin 1, circuit 56 (DB/OG), harness side; and between windshield wiper high/low relay connector pin 4, circuit 58 (WH), harness side and windshield wiper motor C151 pin 2, circuit 58 (WH), harness side.

- Are the resistances less than 5 ohms?

→ Yes  
GO to [D9](#).

→ No  
REPAIR the circuit in question. CLEAR the DTCs. REPEAT the self-test.

**D9 CHECK THE WINDSHIELD WIPER MOTOR**

1 Carry out the windshield wiper motor component test as outlined in this Section.

- Does the wiper motor pass the component test?

→ Yes  
The concern may be intermittent. RE-CONNECT the connectors. CLEAR the DTCs. TEST the system for normal operation. VERIFY the concern.

→ No  
REFER to Windshield Wiper Motor Component Test in this section. CLEAR the DTCs. REPEAT the self-test.

**D10 CHECK CIRCUIT 647 (GY/LB) FOR A SHORT TO VOLTAGE**

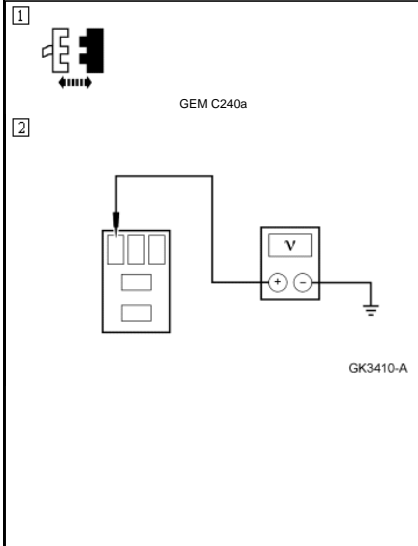

2 Measure the voltage between windshield wiper high/low relay connector pin 2, circuit 647 (GY/LB), harness side and ground.

- Is the voltage greater than 10 volts?

→ Yes  
REPAIR the circuit. CLEAR the DTCs. REPEAT the self-test.

→ No  
GO to [D11](#).

**D11 CHECK CIRCUIT 647 (GY/LB) FOR AN OPEN**

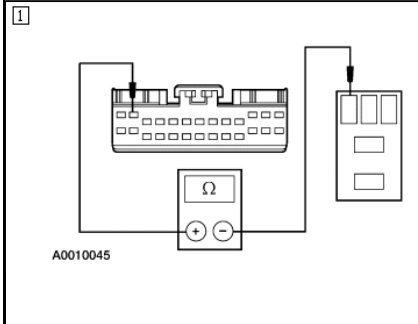

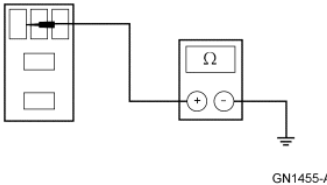

1 Measure the resistance between windshield wiper high/low relay connector pin 2, circuit 647 (GY/LB), harness side and GEM C240a pin 2, circuit 647 (GY/LB), harness side.

- Is the resistance less than 5 ohms?

	<p>→ <b>Yes</b> GO to <a href="#">D12</a>.</p> <p>→ <b>No</b> REPAIR the circuit. CLEAR the DTCs. REPEAT the self-test.</p>
<p><b>D12 CHECK CIRCUIT 647 (GY/LB) FOR A SHORT TO GROUND</b></p>	
<p>1</p> 	<p>1 Measure the resistance between windshield wiper high/low relay connector pin 2, circuit 647 (GY/LB), and ground.</p> <ul style="list-style-type: none"> <li>• <b>Is the resistance greater than 10,000 ohms?</b></li> </ul> <p>→ <b>Yes</b> GO to <a href="#">D13</a>.</p> <p>→ <b>No</b> REPAIR the circuit. CLEAR the DTCs. REPEAT the self-test.</p>
<p><b>D13 CHECK FOR CORRECT GEM OPERATION</b></p>	
	<p>1 Disconnect all GEM connectors.</p> <p>2 Check:</p> <ul style="list-style-type: none"> <li>• for corrosion</li> <li>• for pushed out pins</li> </ul> <p>3 Connect all GEM connectors and make sure they seat correctly.</p> <p>4 Operate the system and verify the concern is still present.</p> <ul style="list-style-type: none"> <li>• <b>Is the concern still present?</b></li> </ul> <p>→ <b>Yes</b> INSTALL a new GEM. REFER to <a href="#">Section 419-10</a>. CLEAR the DTCs. REPEAT the self-test.</p> <p>→ <b>No</b> The system is operating correctly at this time. Concern may have been caused by a loose or corroded connector. CLEAR the DTCs. REPEAT the self-test.</p>

**PINPOINT TEST E: THE INTERMITTENT WINDSHIELD WIPER SPEED DOES NOT OPERATE CORRECTLY**

CONDITIONS	DETAILS/RESULTS/ACTIONS
<p><b>E1 RETRIEVE THE GENERIC ELECTRONIC MODULE (GEM) DIAGNOSTIC TROUBLE CODES (DTCs)</b></p>	
	<p>1 Using the recorded results from the GEM front wiper self-test:</p> <ul style="list-style-type: none"> <li>• <b>Are any DTCs recorded?</b></li> </ul> <p>→ <b>Yes</b> If DTC B1450, GO to <a href="#">E3</a> . If DTCs B1446, B1473, and B1476 are all recorded, GO to <a href="#">E6</a> .</p> <p>→ <b>No</b> GO to <a href="#">E2</a>.</p>
<p><b>E2 MONITOR THE GEM PID WPMODE</b></p>	
<p>1</p>  <p>2</p> 	<p>2 Monitor GEM PID WPMODE while selecting each of the windshield wiper multifunction switch positions.</p> <ul style="list-style-type: none"> <li>• <b>Do the GEM PID values agree with the multifunction switch positions?</b></li> </ul> <p>→ <b>Yes</b> GO to <a href="#">E6</a>.</p> <p>→ <b>No</b> GO to <a href="#">E3</a>.</p>
<p><b>E3 CHECK THE MULTIFUNCTION SWITCH</b></p>	
<p>1</p>	



2 Disconnect multifunction switch C230a and C230b.  
 3 Carry out the multifunction switch component test. Refer to the Wiring Diagram Manual Cell 149.

- Did the multifunction switch pass the component test?

→ Yes  
 GO to E4.

→ No  
 INSTALL a new multifunction switch. REFER to Section 211-05. CLEAR the DTCs. REPEAT the self-test.

**E4 CHECK CIRCUIT 680 (LB/OG) FOR A SHORT TO VOLTAGE**

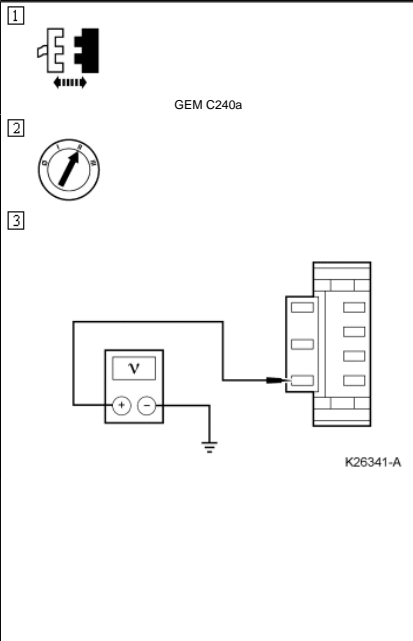

3 Measure the voltage between multifunction switch C230a pin 590, circuit 680 (LB/OG), harness side and ground.

- Is voltage present?

→ Yes  
 REPAIR the circuit. CLEAR the DTCs. REPEAT the self-test.

→ No  
 GO to E5.

**E5 CHECK CIRCUIT 680 (LB/OG) FOR AN OPEN**

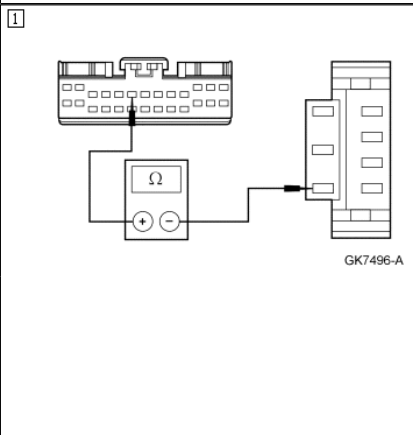

1 Measure the resistance between GEM C240a pin 6, circuit 680 (LB/OG), harness side and multifunction switch C230a pin 590, circuit 680 (LB/OG), harness side.

- Is the resistance less than 5 ohms?

→ Yes  
 GO to E9.

→ No  
 REPAIR the circuit. CLEAR the DTCs. REPEAT the self-test.

**E6 CHECK THE WINDSHIELD WIPER RUN/PARK RELAY**



1 Carry out the relay component test on the windshield wiper run/park relay. Refer to the Wiring Diagram Manual, cell 149.

- Did the windshield wiper run/park relay pass the component test?

→ Yes  
 GO to E7.

→ No  
 INSTALL a new windshield wiper run/park relay. CLEAR the DTCs. REPEAT the self-test.

**E7 CHECK CIRCUIT 671 (LB) FOR AN OPEN**

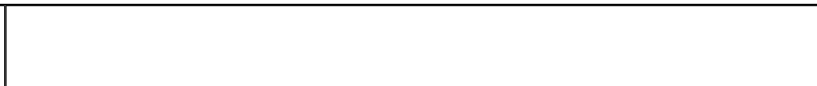
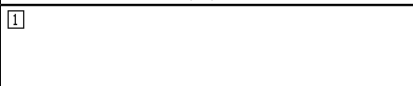

Windshield Wiper Motor C151

GEM C240a

A0010046

3 Measure the resistance between windshield wiper run/park relay connector pin 4, circuit 671 (LB), harness side and GEM C240a pin 14, circuit 671 (LB), harness side; and between windshield wiper motor C151 pin 5, circuit 671 (LB), harness side and GEM C240a pin 14, circuit 671 (LB) harness side.

- Are the resistances less than 5 ohms?

→ Yes  
GO to [E8](#).

→ No  
REPAIR the circuit. CLEAR the DTCs. REPEAT the self-test.

**E8 CHECK THE WINDSHIELD WIPER MOTOR PARK POSITION STATUS— MONITOR THE GEM PID WPPRKS**

GEM PID WPPRKS

A0010047

3 Monitor the GEM PID WPPRKS while connecting and disconnecting a fused jumper wire between windshield wiper motor C151 pin 5, circuit 671 (LB), harness side and ground.

- Does the GEM PID WPPRKS indicate PARKED when pin 1 is grounded and notPRK when the ground is removed?

→ Yes  
REFER to Windshield Wiper Motor Component Test in this section. CLEAR the DTCs. REPEAT the self-test.

→ No  
GO to [E9](#).

**E9 CHECK FOR CORRECT GEM OPERATION**

1 Disconnect all GEM connectors.

2 Check:

- for corrosion
- for pushed out pins

3 Connect all GEM connectors and make sure they seat correctly.







4 Operate the system and verify the concern is still present.

- Is the concern still present?

→ Yes  
INSTALL a new GEM. REFER to [Section 419-10](#). CLEAR the DTCs. REPEAT the self-test.

→ No  
The system is operating correctly at this time. Concern may have been caused by a loose or corroded connector. CLEAR the DTCs. REPEAT the self-test.

**PINPOINT TEST F: THE WINDSHIELD WIPER WASH AND WIPE FUNCTION DOES NOT OPERATE**

CONDITIONS	DETAILS/RESULTS/ACTIONS
<b>F1 RETRIEVE THE RECORDED GENERIC ELECTRONIC MODULE (GEM) DIAGNOSTIC TROUBLE CODES (DTCs)</b>	
	<p>1 Using the recorded results from the GEM front wiper self-test:</p> <ul style="list-style-type: none"> <li>• <b>Are any DTCs recorded?</b></li> </ul> <p>→ <b>Yes</b> If DTC B1450, GO to <a href="#">F4</a> . If DTC B1453, GO to <a href="#">F4</a> . If DTC 1458, GO to <a href="#">F8</a> . If DTC B1460, GO to <a href="#">F8</a> .</p> <p>→ <b>No</b> GO to <a href="#">F2</a> .</p>
<b>F2 MONITOR THE GEM PIDs WPMODE AND WASH_SW</b>	
<p>1 </p> <p>2 </p>	<p>2 Monitor GEM PIDs WPMODE AND WASH_SW while selecting each of the windshield wiper multifunction switch positions and depressing the windshield washer switch.</p> <ul style="list-style-type: none"> <li>• <b>Do the GEM PID values agree with the multifunction switch positions?</b></li> </ul> <p>→ <b>Yes</b> GO to <a href="#">F3</a> .</p> <p>→ <b>No</b> GO to <a href="#">F4</a> .</p>
<b>F3 CHECK THE WASHER PUMP OPERATION USING ACTIVE COMMAND WASH RLY</b>	
<p>1 </p> <p>2 </p>	<p>2 Select GEM active command WASH RLY. Trigger WASH RLY to the ON and OFF positions.</p> <ul style="list-style-type: none"> <li>• <b>Does the windshield washer activate and deactivate correctly when WASH RLY is triggered ON and OFF?</b></li> </ul> <p>→ <b>Yes</b> GO to <a href="#">F15</a> .</p> <p>→ <b>No</b> GO to <a href="#">F7</a> .</p>
<b>F4 CHECK THE MULTIFUNCTION SWITCH</b>	
<p>1 </p>	<p>2 Disconnect multifunction switch C230a and C230b.</p> <p>3 Carry out the multifunction switch component test. Refer to the Wiring Diagram Manual, cell 149.</p> <ul style="list-style-type: none"> <li>• <b>Did the multifunction switch pass the component test?</b></li> </ul> <p>→ <b>Yes</b> GO to <a href="#">F5</a> .</p> <p>→ <b>No</b> INSTALL a new multifunction switch. REFER to <a href="#">Section 211-05</a> . CLEAR the DTCs. REPEAT the self-test.</p>
<b>F5 CHECK CIRCUIT 680 (LB/OG) FOR AN OPEN</b>	
<p>1 </p> <p>GEM C240a</p> <p>2</p>	<p>2 Measure the resistance between GEM C240a pin 6, circuit 680 (LB/OG), harness side and multifunction switch C230a pin 590, circuit 680 (LB/OG), harness side.</p>

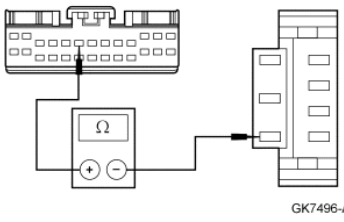

GK7496-A

- Is the resistance less than 5 ohms?

→ **Yes**  
GO to [F6](#).

→ **No**  
REPAIR the circuit. CLEAR the DTCs. REPEAT the self-test.

**F6 CHECK CIRCUIT 680 (LB/OG) FOR A SHORT TO GROUND**

1

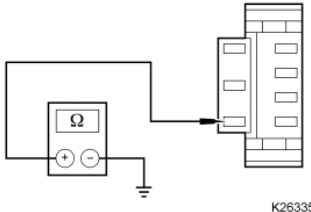

K26335-A

1 Measure the resistance between multifunction switch C230a pin 590, circuit 680 (LB/OG), and ground.

- Is the resistance greater than 10,000 ohms?

→ **Yes**  
GO to [F15](#).

→ **No**  
REPAIR the circuit. CLEAR the DTCs. REPEAT the self-test.

**F7 CHECK THE REAR WINDOW WASHER OPERATION WITH THE WINDSHIELD WASHER RELAY DISCONNECTED**

1



Windshield Washer Relay

2

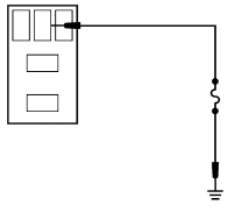

A0015007

3



2 Place a fused jumper between rear washer relay pin 4, circuit 57 (BK), harness side and ground.

4 Activate the rear window washer by selecting the multifunction switch to the rear window washer on position.

- Does the rear window washer operate?

→ **Yes**  
GO to [F8](#).

→ **No**  
GO to [F9](#).

**F8 CHECK CIRCUIT 946 (PK/LG) FOR A SHORT TO GROUND**

1



Washer Pump Motor C1030

2

2 Measure the resistance between windshield washer relay connector pin 3, (for Excursion circuit 946 [PK/LG], for Super Duty, circuit 950 [PK/LG] ) harness side and ground.

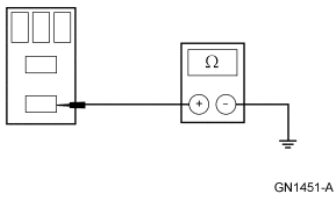



GN1451-A

- Is the resistance greater than 10,000 ohms?

→ **Yes**  
INSTALL a new washer pump. REFER to [Washer Pump and Reservoir](#). CLEAR the DTCs. REPEAT the self-test.

→ **No**  
REPAIR the circuit. CLEAR the DTCs. REPEAT the self-test.

**F9 CHECK CIRCUITS 297 (BK/LG) AND 950 (WH/BK) FOR AN OPEN**

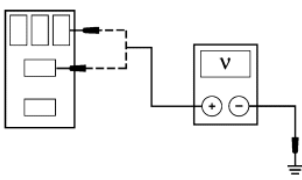
- 1  Windshield Washer Relay
- 2 
- 3  A0010037

- 3 Measure the voltage between windshield washer relay connector pin 5 (for Excursion, circuit 950 [WH/BK], for Super Duty circuit 941, [WH/BK]), harness side and ground; and between windshield washer relay connector pin 1, (for Excursion, circuit 686 [BK/LG], for Super Duty, circuit 297 [BK/LG]), harness side and ground.

- Are the voltages greater than 10 volts?

→ **Yes**  
GO to [F10](#).

→ **No**  
REPAIR the circuit in question. CLEAR the DTCs. REPEAT the self-test.

**F10 CHECK THE WINDSHIELD AND REAR WINDOW WASHER RELAYS**

- 1 Carry out the relay component test on the windshield washer and rear window washer relay. Refer to the Wiring Diagram Manual, cell 149.

- Did the washer relays pass the component test?

→ **Yes**  
For Excursion, GO to [F11](#). For Super Duty, GO to [F12](#).

→ **No**  
INSTALL a new relay. CLEAR the DTCs. REPEAT the self-test.

**F11 CHECK CIRCUIT 57 (BK) FOR AN OPEN**

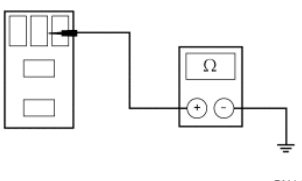
- 1  GN1454-A

- 1 Measure the resistance between rear window washer pump relay connector pin 4 circuit 57 (BK), harness side and ground.

- Is the resistance less than 5 ohms?

→ **Yes**  
GO to [F12](#).

→ **No**

REPAIR the circuit. CLEAR the DTCs. REPEAT the self-test.

**F12 CHECK CIRCUIT 686 (NA/RD) FOR AN OPEN**

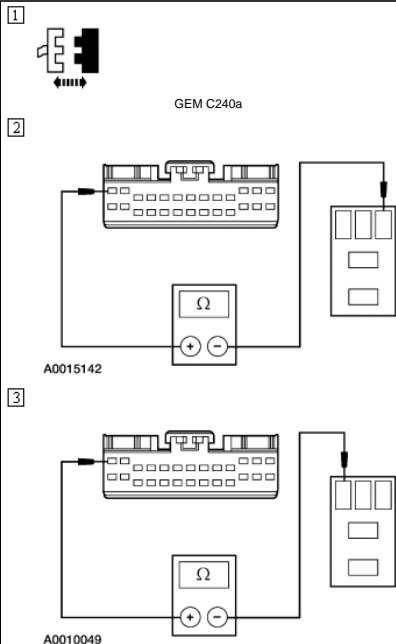

2 For Excursion, measure the resistance between windshield washer relay connector pin 1, circuit 686 (NA/RD), harness side and GEM 240a pin 1, circuit 686 (NA/RD), harness side and ground.

3 For Super Duty, measure the resistance between windshield washer relay connector pin 2, circuit 686 (NA/RD), harness side and GEM C240a pin 1, circuit 686 (NA/RD), harness side.

- Is the resistance less than 5 ohms?

→ Yes  
GO to F13.

→ No  
REPAIR the circuit. CLEAR the DTCs. REPEAT the self-test.

**F13 CHECK CIRCUIT 686 (NA/RD) FOR A SHORT TO VOLTAGE**

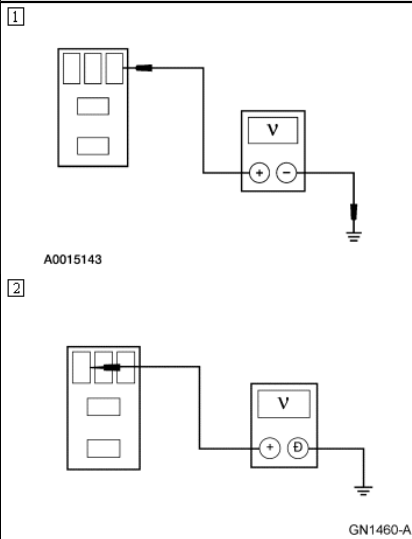

1 For Excursion, measure the voltage between windshield washer relay connector pin 1, circuit 686 (NA/RD), harness side and ground.

2 For Super Duty, measure the voltage between windshield washer relay connector pin 2, circuit 686 (NA/RD), harness side and ground.

- Is any voltage indicated?

→ Yes  
REPAIR the circuit. CLEAR the DTCs. REPEAT the self-test.

→ No  
GO to F14.

**F14 CHECK CIRCUIT 686 (NA/RD) FOR A SHORT TO GROUND**



1 Measure the resistance between windshield washer relay connector pin 2, circuit 686 (NA/RD), and ground.

GN1455-A

- Is the resistance greater than 10,000 ohms?

→ **Yes**  
GO to [F15](#).

→ **No**  
REPAIR the circuit. CLEAR the DTCs. REPEAT the self-test.



**F15 CHECK FOR CORRECT GEM OPERATION**

- 1 Disconnect all GEM connectors.
- 2 Check:
  - for corrosion
  - for pushed out pins
- 3 Connect all GEM connectors and make sure they seat correctly.
- 4 Operate the system and verify the concern is still present.
  - Is the concern still present?

→ **Yes**  
INSTALL a new GEM. REFER to [Section 419-10](#). CLEAR the DTCs. REPEAT the self-test.

→ **No**  
The system is operating correctly at this time. Concern may have been caused by a loose or corroded connector. CLEAR the DTCs. REPEAT the self-test.

**PINPOINT TEST G: THE WINDSHIELD WIPER SPEED DEPENDENT INTERVAL MODE DOES NOT OPERATE CORRECTLY**

CONDITIONS	DETAILS/RESULTS/ACTIONS
<b>G1 RETRIEVE RECORDED GENERIC ELECTRONIC MODULE (GEM) DIAGNOSTIC TROUBLE CODES (DTCs)</b>	
	<ol style="list-style-type: none"> <li>1 Using the recorded results from the GEM front wiper self-test:                             <ul style="list-style-type: none"> <li>• Are any DTCs recorded?</li> </ul> </li> </ol> <p>→ <b>Yes</b> If DTC B1446, GO to <a href="#">G6</a>.</p> <p>→ <b>No</b> GO to <a href="#">G2</a>.</p>
<b>G2 CHECK THE VSS — MONITOR THE GEM PID VSS</b>	
<ol style="list-style-type: none"> <li>1 </li> </ol>	<ol style="list-style-type: none"> <li>1 Monitor ABS PIDs LF_WSPD, RF_WSPD, R_WSSP and GEM PID VSS while driving the vehicle from 0 to 88.5 kph (55 mph).                             <ul style="list-style-type: none"> <li>• Does the GEM PID VSS agree with the ABS PIDs LF_WSPD, RF_WSPD, R_WSSP and GEM PID VSS?</li> </ul> </li> </ol> <p>→ <b>Yes</b> GO to <a href="#">G9</a>.</p> <p>→ <b>No</b> GO to <a href="#">G3</a>.</p>
<b>G3 CHECK THE CENTRAL JUNCTION BOX (CJB) FOR AN OPEN</b>	
<ol style="list-style-type: none"> <li>1  GEM C240d</li> <li>2  CJB C242b</li> <li>3</li> </ol>	<ol style="list-style-type: none"> <li>3 Measure the resistance between GEM C240d pin 18, harness (CJB) side and CJB C242b pin 21, circuit 679 (GY/BK), component (CJB) side.</li> </ol>

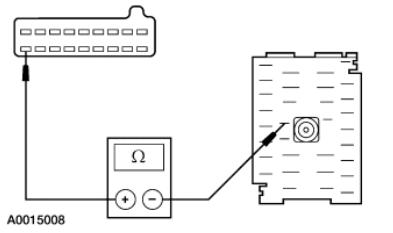
 <p>A0015008</p>	<ul style="list-style-type: none"> <li>• Is the resistance less than 5 ohms?</li> </ul> <p>→ <b>Yes</b> GO to <a href="#">G4</a>.</p> <p>→ <b>No</b> REPAIR the CJB as necessary. CLEAR the DTCs. REPEAT the self-test.</p>
---	---

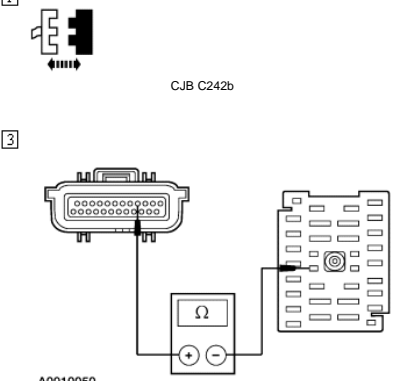
<p><b>G4 CHECK CIRCUIT 679 (GY/BK) FOR AN OPEN</b></p>	
<p>1</p>  <p>A0010050</p>	<p>2 Disconnect anti-lock brake control module C1040a.</p> <p>3 Measure the resistance between anti-lock brake control module C1040a pin 16, circuit 679 (GY/BK), harness side and CJB C242b pin 21, circuit 679 (GY/BK), harness side.</p> <ul style="list-style-type: none"> <li>• Is the resistance less than 5 ohms?</li> </ul> <p>→ <b>Yes</b> GO to <a href="#">G5</a>.</p> <p>→ <b>No</b> REPAIR the circuit. CLEAR the DTCs. REPEAT the self-test.</p>

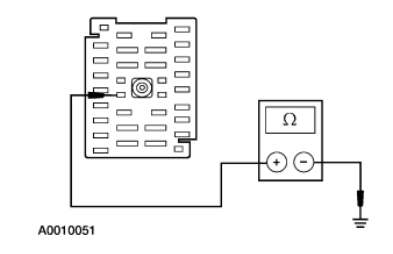
<p><b>G5 CHECK CIRCUIT 679 (GY/BK) FOR A SHORT TO GROUND</b></p>	
<p>1</p>  <p>A0010051</p>	<p>1 Measure the resistance between CJB C242b pin 21, circuit 679 (GY/BK), harness side and ground.</p> <ul style="list-style-type: none"> <li>• Is the resistance greater than 10,000 ohms?</li> </ul> <p>→ <b>Yes</b> DIAGNOSE the anti-lock brake control system. REFER to <a href="#">Section 206-09A</a> or <a href="#">Section 206-09B</a>.</p> <p>→ <b>No</b> REPAIR the circuit. CLEAR the DTCs. REPEAT the self-test.</p>



<p><b>G6 MONITOR THE GEM PID WPPRKS</b></p>	
<p>1</p>  <p>2</p>	<p>2 Monitor GEM PID WPPRKS while selecting the multifunction switch to the windshield wiper on and off positions.</p> <ul style="list-style-type: none"> <li>• Does the GEM PID WPPRKS indicate PARKED when the windshield wipers are off?</li> </ul>

	<p>→ <b>Yes</b> GO to <a href="#">G9</a>.</p> <p>→ <b>No</b> GO to <a href="#">G7</a>.</p>
--	--

**G7 CHECK THE WINDSHIELD WIPER RUN/PARK RELAY**

<p>1</p> 	<p>2 Disconnect the windshield wiper run/park relay.</p> <p>3 Carry out the relay component test on the windshield wiper run/park relay. Refer to the Wiring Diagram Manual Cell 149.</p> <ul style="list-style-type: none"> <li>• <b>Did the windshield wiper run/park relay pass the component test?</b></li> </ul> <p>→ <b>Yes</b> GO to <a href="#">G8</a>.</p> <p>→ <b>No</b> INSTALL a new windshield wiper run/park relay. CLEAR the DTCs. REPEAT the self-test.</p>
--	---

**G8 CHECK CIRCUIT 671 (LB) FOR AN OPEN**

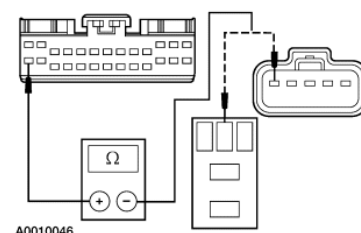



<p>1</p>  <p>Windshield Wiper Motor C151</p> <p>2</p>  <p>GEM C240a</p> <p>3</p>  <p>A0010046</p>	<p>3 Measure the resistance between GEM C240a pin 14, circuit 671 (LB) harness side and windshield wiper motor C151 pin 5, circuit 671 (LB) harness side; and between GEM C240a pin 14, circuit 671 (LB) harness side and windshield wiper run/park relay connector pin 4, circuit 671 (LB), harness side.</p> <ul style="list-style-type: none"> <li>• <b>Are the resistances both less than 5 ohms?</b></li> </ul> <p>→ <b>Yes</b> REFER to Windshield Wiper Motor Component Test in this section. CLEAR the DTCs. REPEAT the self-test.</p> <p>→ <b>No</b> REPAIR the circuit. CLEAR the DTCs. REPEAT the self-test.</p>
---	---

**G9 CHECK FOR CORRECT GEM OPERATION**

	<p>1 Disconnect all GEM connectors.</p> <p>2 Check:</p> <ul style="list-style-type: none"> <li>• for corrosion</li> <li>• for pushed out pins</li> </ul> <p>3 Connect all GEM connectors and make sure they seat correctly.</p> <p>4 Operate the system and verify the concern is still present.</p> <ul style="list-style-type: none"> <li>• <b>Is the concern still present?</b></li> </ul> <p>→ <b>Yes</b> INSTALL a new GEM. REFER to <a href="#">Section 419-10</a>. CLEAR the DTCs. REPEAT the self-test.</p> <p>→ <b>No</b> The system is operating correctly at this time. Concern may have been caused by a loose or corroded connector. CLEAR the DTCs. REPEAT the self-test.</p>
--	---

**PINPOINT TEST H: THE REAR WINDOW WIPERS ARE INOPERATIVE**

CONDITIONS	DETAILS/RESULTS/ACTIONS
<b>H1 CHECK THE FRONT WINDSHIELD WIPER OPERATION</b>	
<p>1</p> 	

	<p>[2] Using the multifunction switch, activate the front windshield wipers on and off.</p> <ul style="list-style-type: none"> <li>• Do the front windshield wipers operate correctly?</li> </ul> <p>→ Yes GO to <a href="#">H2</a>.</p> <p>→ No GO to <a href="#">Pinpoint Test L</a>.</p>
<p><b>H2 RETRIEVE RECORDED GENERIC ELECTRONIC MODULE (GEM) DIAGNOSTIC TROUBLE CODES (DTCs)</b></p>	
<p>[1]</p> 	<p>[2] Using the recorded results from the GEM rear wiper self-test:</p> <ul style="list-style-type: none"> <li>• Are any DTCs recorded?</li> </ul> <p>→ Yes If DTC B1240, GO to <a href="#">Pinpoint Test K</a>. If DTC B1241, GO to <a href="#">Pinpoint Test K</a>. If DTC B1611, GO to <a href="#">H5</a>. If DTC B1614, GO to <a href="#">Pinpoint Test J</a>. If DTC B1820, GO to <a href="#">H10</a>. If DTC B1839, GO to <a href="#">H7</a>.</p> <p>→ No GO to <a href="#">H3</a>.</p>
<p><b>H3 MONITOR THE GEM PID R_WP_MD</b></p>	
<p>[1]</p>  <p>[2]</p> 	<p>[2] Monitor GEM PID R_WP_MD while selecting each of the multifunction switch windshield wiper positions.</p> <ul style="list-style-type: none"> <li>• Do the GEM PID values agree with the multifunction switch positions?</li> </ul> <p>→ Yes GO to <a href="#">H4</a>.</p> <p>→ No GO to <a href="#">H5</a>.</p>
<p><b>H4 CHECK THE REAR WINDOW WIPER MOTOR OPERATION USING ACTIVE COMMAND UP RELAY</b></p>	
<p>[1]</p> 	<p>[1] Select GEM active command UP RELAY. Trigger UP RELAY to the ON and OFF positions.</p> <ul style="list-style-type: none"> <li>• Does the rear window wiper motor activate and deactivate correctly when UP RELAY is triggered ON and OFF?</li> </ul> <p>→ Yes GO to <a href="#">H16</a>.</p> <p>→ No GO to <a href="#">H7</a>.</p>
<p><b>H5 CHECK THE MULTIFUNCTION SWITCH</b></p>	
<p>[1]</p> 	<p>[2] Disconnect multifunction switch C230a and C230b. [3] Carry out the multifunction switch component test. Refer to the Wiring Diagram Manual Cell 149.</p> <ul style="list-style-type: none"> <li>• Did the multifunction switch pass the component test?</li> </ul> <p>→ Yes GO to <a href="#">H6</a>.</p> <p>→ No INSTALL a new multifunction switch. REFER to <a href="#">Section 211-05</a>. CLEAR the DTCs. REPEAT the self-test.</p>
<p><b>H6 CHECK CIRCUIT 485 (PK/BK) FOR AN OPEN</b></p>	
<p>[1]</p>	

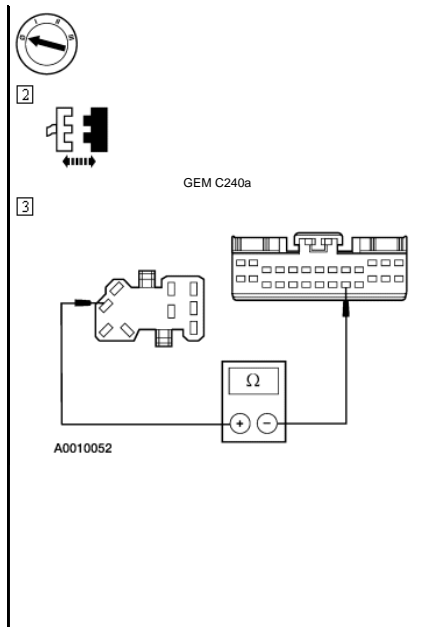

3 Measure the resistance between multifunction switch C230b pin 380, circuit 485 (PK/BK), harness side and GEM C240a pin 22, circuit 485 (PK/BK), harness side.

- Is the resistance less than 5 ohms?

→ Yes  
GO to [H16](#).

→ No  
REPAIR the circuit. CLEAR the DTCs. REPEAT the self-test.

**H7 CHECK BATTERY JUNCTION BOX (BJB) FUSE 1 (20A) FOR VOLTAGE**

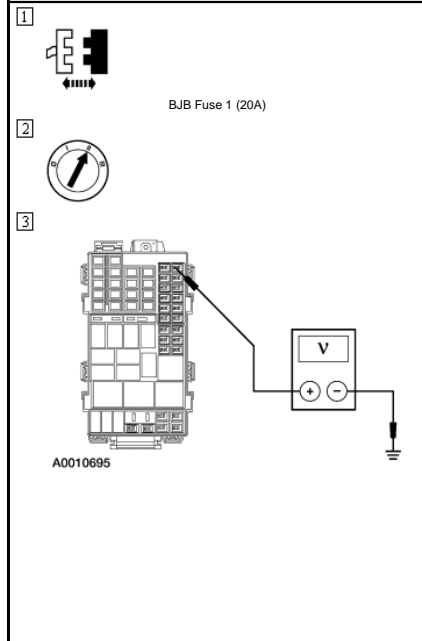

3 Measure the voltage between BJB Fuse 1 (20A) input terminal, harness side and ground.

- Is the voltage greater than 10 volts?

→ Yes  
RECONNECT BJB Fuse 1 (20A), GO to [H8](#) .

→ No  
REPAIR the BJB as necessary. CLEAR the DTCs. REPEAT the self-test.

**H8 CHECK CIRCUIT 297 (BK/LG) AND 406 (BN/WH) FOR AN OPEN**

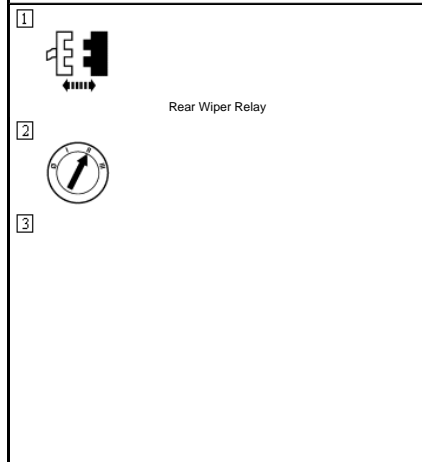

3 Measure the voltage between rear window wiper relay pin 1, circuit 297 (BK/LG), harness side and ground; and between rear window wiper relay pin 5, circuit 406 (BN/WH), harness side and ground.

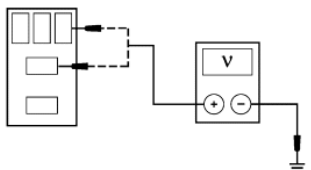
 <p>A0010037</p>	<ul style="list-style-type: none"> <li>• Is voltage present?</li> </ul> <p>→ Yes GO to <a href="#">H9</a>.</p> <p>→ No REPAIR the circuit in question. CLEAR the DTCs. REPEAT the self-test.</p>
---	--

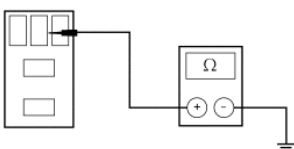
<p><b>H9 CHECK CIRCUIT 57 (BK) FOR AN OPEN</b></p>	
<p>1</p>  <p>2</p>  <p>GN1454-A</p>	<p>2 Measure the resistance between rear window wiper relay connector pin 4, circuit 57 (BK), harness side and ground.</p> <ul style="list-style-type: none"> <li>• Is the resistance less than 5 ohms?</li> </ul> <p>→ Yes GO to <a href="#">H10</a>.</p> <p>→ No REPAIR circuit 56 (DB/O) and/or circuit 58 (WH). CLEAR the DTCs. TEST the system for normal operation.</p>

<p><b>H10 CHECK THE REAR WINDOW WIPER RELAY</b></p>	
<p>1</p> 	<p>2 Carry out the relay component test on the rear window wiper relay. Refer to the Wiring Diagram Manual, cell 149.</p> <ul style="list-style-type: none"> <li>• Did the rear window wiper relay pass the component test?</li> </ul> <p>→ Yes GO to <a href="#">H11</a>.</p> <p>→ No INSTALL a new relay. CLEAR the DTCs. REPEAT the self-test.</p>

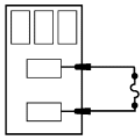
<p><b>H11 CHECK THE REAR WINDOW WIPER MOTOR FUNCTION</b></p>	
<p>1</p>  <p>2</p>  <p>A0010054</p>	<p>2 Connect a fused jumper wire between rear window wiper relay connector pin 5, circuit 406 (BN/WH), harness side and rear window wiper relay connector pin 3, circuit 410 (WH/OG), harness side.</p> <ul style="list-style-type: none"> <li>• Does the rear window wiper motor operate?</li> </ul> <p>→ Yes</p>

GO to [H12](#).  
 → No  
 GO to [H14](#).

**H12 CHECK CIRCUIT 591 (LG) FOR A SHORT TO VOLTAGE**

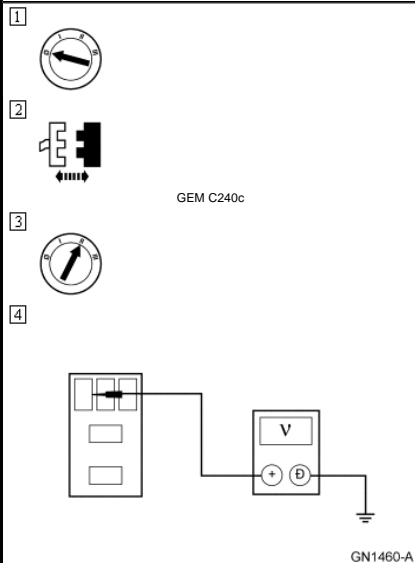

4 Measure the voltage between rear window wiper relay connector pin 2, circuit 591 (LG), harness side and ground.

• Is voltage present?  
 → Yes  
 REPAIR the circuit. CLEAR the DTCs. REPEAT the self-test.  
 → No  
 GO to [H13](#).

**H13 CHECK CIRCUIT 591 (LG) FOR AN OPEN**

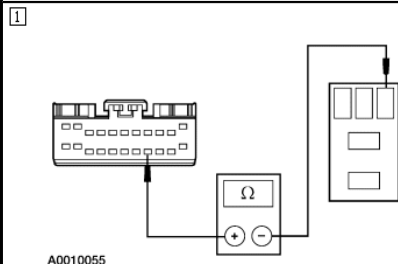

1 Measure the resistance between rear window wiper relay connector pin 2, circuit 591 (LG), harness side and GEM C240c pin 19, circuit 591 (LG).

• Is the resistance less than 5 ohms?  
 → Yes  
 GO to [H16](#).  
 → No  
 REPAIR the circuit. CLEAR the DTCs. REPEAT the self-test.

**H14 CHECK CIRCUITS 410 (WH/OG) AND 406 (BN/WH) FOR AN OPEN**

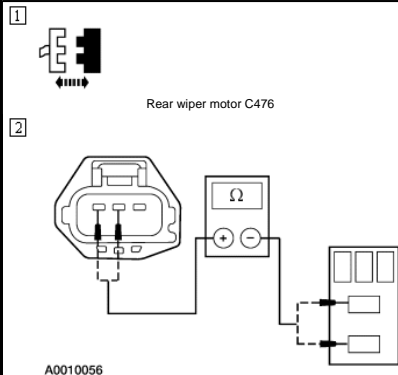





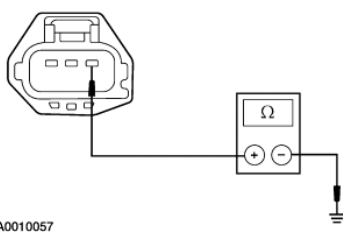



2 Measure the resistance between rear window wiper motor relay pin 3, circuit 410 (WH/OG), harness side and rear window wiper motor C476 pin 2, circuit 410 (WH/OG), harness side; and between rear window wiper motor relay pin 5, circuit 406 (BN/WH), harness side and rear window wiper motor C476 pin 3, circuit 406 (BN/WH), harness side.





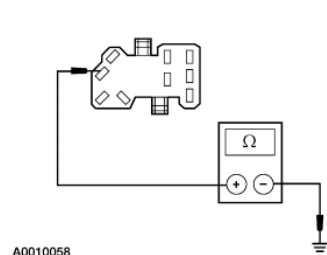

• Are the resistances less than 5 ohms?

	<p>→ <b>Yes</b> GO to <a href="#">H15</a>.</p> <p>→ <b>No</b> REPAIR the circuit in question. CLEAR the DTCs. REPEAT the self-test.</p>
<p><b>H15 CHECK CIRCUIT 57 (BK) FOR AN OPEN</b></p>	
<p>1</p>  <p>A0010057</p>	<p>1 Measure the resistance between rear window wiper motor pin 1, circuit 57 (BK), harness side, and ground.</p> <ul style="list-style-type: none"> <li>• <b>Is the resistance less than 5 ohms?</b></li> </ul> <p>→ <b>Yes</b> INSTALL a new rear window wiper motor. REFER to <a href="#">Rear Window Wiper Motor</a> in this Section. CLEAR the DTCs. REPEAT the self-test.</p> <p>→ <b>No</b> REPAIR the circuit. CLEAR the DTCs. REPEAT the self-test.</p>
<p><b>H16 CHECK FOR CORRECT GEM OPERATION</b></p>	
	<p>1 Disconnect all GEM connectors.</p> <p>2 Check:</p> <ul style="list-style-type: none"> <li>• for corrosion</li> <li>• for pushed out pins</li> </ul> <p>3 Connect all GEM connectors and make sure they seat correctly.</p> <p>4 Operate the system and verify the concern is still present.</p> <ul style="list-style-type: none"> <li>• <b>Is the concern still present?</b></li> </ul> <p>→ <b>Yes</b> INSTALL a new GEM. REFER to <a href="#">Section 419-10</a>. CLEAR the DTCs. REPEAT the self-test.</p> <p>→ <b>No</b> The system is operating correctly at this time. Concern may have been caused by a loose or corroded connector. CLEAR the DTCs. REPEAT the self-test.</p>

**PINPOINT TEST I: THE REAR WINDOW WIPERS STAY ON CONTINUOUSLY**

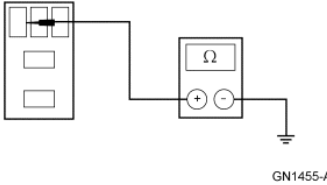
CONDITIONS	DETAILS/RESULTS/ACTIONS
<p><b>I1 CHECK THE WINDSHIELD WIPER OPERATION</b></p>	
<p>1</p> 	<p>2 Using the multifunction switch, activate the windshield wiper motor on and off.</p> <ul style="list-style-type: none"> <li>• <b>Does the windshield wiper motor operate correctly?</b></li> </ul> <p>→ <b>Yes</b> GO to <a href="#">I2</a>.</p> <p>→ <b>No</b> GO to <a href="#">Pinpoint Test L</a>.</p>
<p><b>I2 RETRIEVE THE RECORDED GENERIC ELECTRONIC MODULE (GEM) DIAGNOSTIC TROUBLE CODES (DTCs)</b></p>	
	<p>1 Using the recorded results from the GEM rear wiper self-test.</p> <ul style="list-style-type: none"> <li>• <b>Are any DTCs retrieved?</b></li> </ul> <p>→ <b>Yes</b> If DTC B1240, GO to <a href="#">Pinpoint Test K</a>. If DTC B1241, GO to <a href="#">Pinpoint Test K</a>. If DTC B1611, GO to <a href="#">Pinpoint Test H</a>. If DTC B1614, GO to <a href="#">I5</a>. If DTC B1820, GO to <a href="#">Pinpoint Test H</a>.</p> <p>→ <b>No</b> GO to <a href="#">I3</a>.</p>

<p><b>13 MONITOR THE GEM PID R_WP_MD</b></p>	
<p>1 </p> <p>2 </p>	<p>3 Monitor GEM PID R_WP_MD while selecting each of the multifunction switch rear window wiper positions.</p> <ul style="list-style-type: none"> <li>• <b>Do the GEM PID values agree with the multifunction switch positions?</b></li> </ul> <p>→ <b>Yes</b> GO to 14.</p> <p>→ <b>No</b> GO to 15.</p>
<p><b>14 CHECK THE REAR WINDOW WIPER MOTOR OPERATION USING ACTIVE COMMAND UP RELAY</b></p>	
<p>1 </p>	<p>1 Select the GEM active command UP RELAY. Trigger UP RELAY to the ON and OFF positions.</p> <ul style="list-style-type: none"> <li>• <b>Does the rear window wiper motor activate and deactivate correctly when UP RELAY is triggered ON and OFF?</b></li> </ul> <p>→ <b>Yes</b> GO to 111.</p> <p>→ <b>No</b> GO to 17.</p>
<p><b>15 CHECK THE MULTIFUNCTION SWITCH</b></p>	
<p>1 </p>	<p>2 Disconnect multifunction switch C230a and C230b.</p> <p>3 Carry out the multifunction switch component test. Refer to the Wiring Diagram Manual, cell 149.</p> <ul style="list-style-type: none"> <li>• <b>Did the multifunction switch pass the component test?</b></li> </ul> <p>→ <b>Yes</b> GO to 16.</p> <p>→ <b>No</b> INSTALL a new multifunction switch. REFER to Section 211-05. CLEAR the DTCs. REPEAT the self-test.</p>
<p><b>16 CHECK CIRCUIT 485 (PK/BK) FOR A SHORT TO GROUND</b></p>	
<p>1 </p> <p>GEM C240a</p> <p>2 </p> <p>A0010058</p>	<p>2 Measure the resistance between multifunction switch C230b pin 380, circuit 485 (PK/BK), harness side and ground.</p> <ul style="list-style-type: none"> <li>• <b>Is the resistance greater than 10,000 ohms?</b></li> </ul> <p>→ <b>Yes</b> GO to 111.</p> <p>→ <b>No</b> REPAIR the circuit. CLEAR the DTCs. REPEAT the self-test.</p>
<p><b>17 CHECK THE REAR WINDOW WIPER MOTOR OPERATION</b></p>	
<p>1 </p> <p>2 </p>	

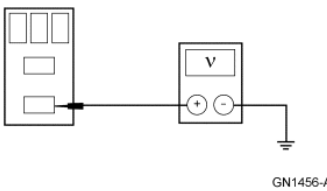
 <p>Rear Wiper Relay</p>	<ul style="list-style-type: none"> <li>• Does the rear window wiper motor deactivate?</li> </ul> <p>→ <b>Yes</b> GO to <a href="#">18</a>.</p> <p>→ <b>No</b> GO to <a href="#">110</a>.</p>
<p><b>18 CHECK THE REAR WINDOW WIPER RELAY</b></p>	
	<p><b>1</b> Carry out the relay component test on the rear window wiper relay. Refer to the Wiring Diagram Manual, cell 149.</p> <ul style="list-style-type: none"> <li>• Did the rear window wiper motor relay pass the component test?</li> </ul> <p>→ <b>Yes</b> GO to <a href="#">19</a>.</p> <p>→ <b>No</b> INSTALL a new relay. CLEAR the DTCs. REPEAT the self-test.</p>
<p><b>19 CHECK CIRCUIT 591 (LG) FOR A SHORT TO GROUND</b></p>	
<p><b>1</b></p>  <p>GEM C240c</p> <p><b>2</b></p>  <p>GN1455-A</p>	<p><b>2</b> Measure the resistance between rear window wiper relay connector pin 2, circuit 591 (LG), harness side and ground.</p> <ul style="list-style-type: none"> <li>• Is the resistance greater than 10,000 ohms?</li> </ul> <p>→ <b>Yes</b> GO to <a href="#">111</a>.</p> <p>→ <b>No</b> REPAIR the circuit. CLEAR the DTCs. REPEAT the self-test.</p>
<p><b>110 CHECK CIRCUIT 410 (WH/OG) FOR A SHORT TO VOLTAGE</b></p>	
<p><b>1</b></p>  <p><b>2</b></p>  <p>Rear wiper motor C476</p> <p><b>3</b></p>  <p><b>4</b></p>  <p>GN1456-A</p>	<p><b>4</b> Measure the voltage between rear window wiper relay connector pin 3, circuit 410 (WH/OG), harness side and ground.</p> <ul style="list-style-type: none"> <li>• Is voltage present?</li> </ul> <p>→ <b>Yes</b> REPAIR the circuit. CLEAR the DTCs. REPEAT the self-test.</p>



	<p>→ <b>No</b> INSTALL a new rear window wiper motor. REFER to <a href="#">Rear Window Wiper Motor</a> in this Section. CLEAR the DTCs. REPEAT the self-test.</p>
<b>I11 CHECK FOR CORRECT GEM OPERATION</b>	
	<p>1 Disconnect all GEM connectors.</p> <p>2 Check:</p> <ul style="list-style-type: none"> <li>• for corrosion</li> <li>• for pushed out pins</li> </ul> <p>3 Connect all GEM connectors and make sure they seat correctly.</p> <p>4 Operate the system and verify the concern is still present.</p> <ul style="list-style-type: none"> <li>• <b>Is the concern still present?</b></li> </ul> <p>→ <b>Yes</b> INSTALL a new GEM. REFER to <a href="#">Section 419-10</a>. CLEAR the DTCs. REPEAT the self-test.</p> <p>→ <b>No</b> The system is operating correctly at this time. Concern may have been caused by a loose or corroded connector. CLEAR the DTCs. REPEAT the self-test.</p>

**PINPOINT TEST J: THE INTERMITTENT REAR WINDOW WIPER SPEED DOES NOT OPERATE CORRECTLY**

CONDITIONS	DETAILS/RESULTS/ACTIONS
<b>J1 RETRIEVE THE RECORDED GENERIC ELECTRONIC MODULE (GEM) DIAGNOSTIC TROUBLE CODES (DTCs)</b>	
	<p>1 Using the recorded results from the GEM rear wiper self-test:</p> <ul style="list-style-type: none"> <li>• <b>Are any DTCs retrieved?</b></li> </ul> <p>→ <b>Yes</b> If DTC B1240, or B1241, GO to <a href="#">Pinpoint Test K</a>. If DTC B1611, B1820, or B1839, GO to <a href="#">Pinpoint Test H</a>. If DTC B1614, GO to <a href="#">Pinpoint Test I</a>.</p> <p>→ <b>No</b> GO to <a href="#">J2</a>.</p>
<b>J2 MONITOR THE GEM PID R_WP_MD</b>	
<p>1 </p> <p>2 </p>	<p>3 Monitor GEM PID R_WP_MD while selecting each of the rear window wiper positions on the multifunction switch.</p> <ul style="list-style-type: none"> <li>• <b>Do the GEM PID values agree with the multifunction switch positions?</b></li> </ul> <p>→ <b>Yes</b> GO to <a href="#">J3</a>.</p> <p>→ <b>No</b> GO to <a href="#">J4</a>.</p>
<b>J3 CHECK THE REAR WINDOW WIPER MOTOR OPERATION USING ACTIVE COMMAND UP RELAY</b>	
<p>1 </p>	<p>1 Select GEM active command UP RELAY. Trigger UP RELAY to the ON and OFF positions.</p> <ul style="list-style-type: none"> <li>• <b>Does the rear window wiper motor activate and deactivate correctly when UP RELAY is triggered ON and OFF?</b></li> </ul> <p>→ <b>Yes</b> GO to <a href="#">J5</a>.</p> <p>→ <b>No</b> GO to <a href="#">Pinpoint Test H</a>.</p>
<b>J4 CHECK THE MULTIFUNCTION SWITCH</b>	
<p>1 </p>	<p>2 Disconnect multifunction switch C230a and C230b.</p> <p>3 Carry out the multifunction switch component test. Refer to the Wiring Diagram Manual, cell 149.</p> <ul style="list-style-type: none"> <li>• <b>Did the multifunction switch pass the component test?</b></li> </ul>



<p>→ <b>Yes</b> GO to <a href="#">J5</a>.</p> <p>→ <b>No</b> INSTALL a new multifunction switch. REFER to <a href="#">Section 211-05</a>. CLEAR the DTCs. REPEAT the self-test.</p>
<p><b>J5 CHECK FOR CORRECT GEM OPERATION</b></p>
<p>1 Disconnect all GEM connectors.</p> <p>2 Check:</p> <ul style="list-style-type: none"> <li>• for corrosion</li> <li>• for pushed out pins</li> </ul> <p>3 Connect all GEM connectors and make sure they seat correctly.</p> <p>4 Operate the system and verify the concern is still present.</p> <ul style="list-style-type: none"> <li>• <b>Is the concern still present?</b></li> </ul> <p>→ <b>Yes</b> INSTALL a new GEM. REFER to <a href="#">Section 419-10</a>. CLEAR the DTCs. REPEAT the self-test.</p> <p>→ <b>No</b> The system is operating correctly at this time. Concern may have been caused by a loose or corroded connector. CLEAR the DTCs. REPEAT the self-test.</p>

**PINPOINT TEST K: THE REAR WINDOW WASH AND WIPE FUNCTION DOES NOT OPERATE**

CONDITIONS	DETAILS/RESULTS/ACTIONS
<p><b>K1 RETRIEVE THE RECORDED GENERIC ELECTRONIC MODULE (GEM) DIAGNOSTIC TROUBLE CODES (DTCs)</b></p>	<p>1 Using the recorded results from the GEM rear wiper self-test:</p> <ul style="list-style-type: none"> <li>• <b>Are any DTCs retrieved?</b></li> </ul> <p>→ <b>Yes</b> If DTC B1240, GO to <a href="#">K7</a> . If DTC B1241, GO to <a href="#">K8</a> . If DTC B1611, GO to <a href="#">Pinpoint Test H</a> . If DTC B1614, GO to <a href="#">Pinpoint Test I</a> . If DTC B1820, GO to <a href="#">Pinpoint Test H</a> . If DTC 1839, GO to <a href="#">Pinpoint Test H</a> .</p> <p>→ <b>No</b> GO to <a href="#">K2</a> .</p>
<p><b>K2 MONITOR THE GEM PID R_WP_MD</b></p> <p>1 </p> <p>2 </p>	<p>3 Monitor GEM PID R_WP_MD while selecting each of the rear window wiper positions on the multifunction switch and depressing the rear window washer switch.</p> <ul style="list-style-type: none"> <li>• <b>Do the GEM PID values agree with the multifunction switch positions?</b></li> </ul> <p>→ <b>Yes</b> GO to <a href="#">K3</a> .</p> <p>→ <b>No</b> If no GEM PID values agree, GO to <a href="#">Pinpoint Test H</a> . If GEM PID value WASH does not agree, GO to <a href="#">K4</a> .</p>
<p><b>K3 CHECK THE WASHER PUMP OPERATION USING ACTIVE COMMAND WASH RLY</b></p> <p>1 </p>	<p>1 Select GEM active command WASH RLY. Trigger GEM active command WASH RLY ON and OFF.</p> <ul style="list-style-type: none"> <li>• <b>Does the rear window washer activate and deactivate correctly when WASH RLY is triggered ON and OFF?</b></li> </ul> <p>→ <b>Yes</b> GO to <a href="#">K13</a> .</p> <p>→ <b>No</b> GO to <a href="#">K5</a> .</p>
<p><b>K4 CHECK THE MULTIFUNCTION SWITCH</b></p>	

<p>1</p> 	<p>2 Disconnect multifunction switch C230a and C230b.</p> <p>3 Carry out the multifunction switch component test. Refer to the Wiring Diagram Manual, cell 149.</p> <ul style="list-style-type: none"> <li>• Did the multifunction switch pass the component test?</li> </ul> <p>→ Yes GO to <a href="#">K13</a>.</p> <p>→ No INSTALL a new multifunction switch. REFER to <a href="#">Section 211-05</a>. CLEAR the DTCs. REPEAT the self-test.</p>
--	--

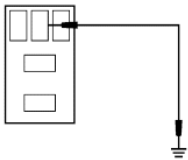
**K5 CHECK THE WINDSHIELD WASHER OPERATION WITH THE REAR WINDOW WASHER RELAY DISCONNECTED**

<p>1</p>  <p>Rear Washer Relay</p> <p>2</p>  <p>A0015144</p> <p>3</p> 	<p>2 Connect a jumper between rear windshield washer relay pin 4, harness side and ground.</p> <p>4 Jump ground across relay.</p> <p>5 Activate the windshield washer from the multifunction switch.</p> <ul style="list-style-type: none"> <li>• Does the windshield washer operate?</li> </ul> <p>→ Yes GO to <a href="#">K6</a>.</p> <p>→ No GO to <a href="#">K7</a>.</p>
---	---

**K6 CHECK CIRCUIT 941 (BK/WH) FOR A SHORT TO GROUND**

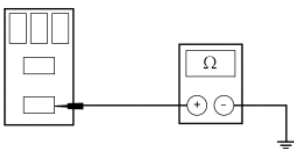
<p>1</p>  <p>Washer Pump Motor C1030</p> <p>2</p>  <p>GN1451-A</p>	<p>2 Measure the resistance between windshield washer relay connector pin 3, circuit 941 (BK/WH), harness side and ground.</p> <ul style="list-style-type: none"> <li>• Is the resistance greater than 10, 000 ohms?</li> </ul> <p>→ Yes INSTALL a new washer pump. REFER to <a href="#">Washer Pump and Reservoir</a>. CLEAR the DTCs. REPEAT the self-test.</p> <p>→ No REPAIR the circuit. CLEAR the DTCs. REPEAT the self-test.</p>
--	---

**K7 CHECK CIRCUITS 297 (BK/LG) AND 950 (WH/BK) FOR AN OPEN**

<p>1</p>	<p>1 Measure the voltage between rear window washer relay connector pin 5 circuit 297 (BK/LG), harness side and ground; and between rear window washer relay connector pin 1, circuit 297 (BK/LG), harness side and ground.</p>
----------	---

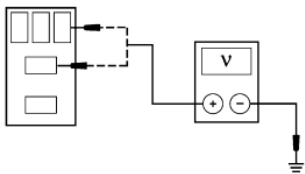

A0010037

- Are the voltages greater than 10 volts?

→ **Yes**  
GO to [K8](#).

→ **No**  
REPAIR the circuit(s) in question. CLEAR the DTCs. REPEAT the self-test.

**K8 CHECK THE WINDSHIELD AND REAR WINDOW WASHER RELAYS**

1 Carry out the relay component test on the windshield and rear window washer relay. Refer to the Wiring Diagram Manual, cell 149.

- Did both relays pass the component test?

→ **Yes**  
GO to [K9](#).

→ **No**  
INSTALL a new relay. CLEAR the DTCs. REPEAT the self-test.

**K9 CHECK CIRCUIT 57 (BK) FOR AN OPEN**

1

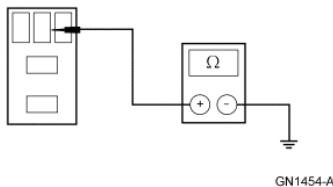

1 Measure the resistance between windshield washer relay connector pin 4 circuit 57 (BK), harness side and ground.

- Is the resistance less than 5 ohms?

→ **Yes**  
GO to [K10](#).

→ **No**  
REPAIR the circuit. CLEAR the DTCs. REPEAT the self-test.

**K10 CHECK CIRCUIT 488 (DG) FOR AN OPEN**

1



2



Rear Washer Relay

3



GEM C240c

4

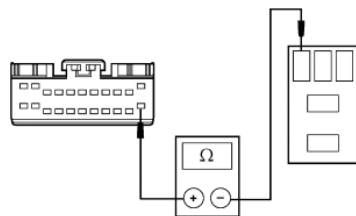

A0010059

4 Measure the resistance between rear window washer relay connector pin 2, circuit 488 (DG), harness side and GEM C240c pin 22, circuit 488 (DG), harness side.

- Is the resistance less than 5 ohms?

	<p>→ <b>Yes</b> GO to <a href="#">K11</a>.</p> <p>→ <b>No</b> REPAIR the circuit. CLEAR the DTCs. REPEAT the self-test.</p>
--	---

**K11 CHECK CIRCUIT 488 (DG) FOR A SHORT TO VOLTAGE**

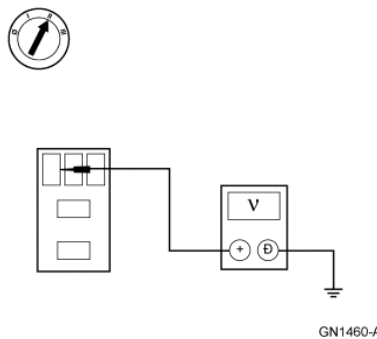
<p>1</p>  <p>2</p>	<p>2 Measure the voltage between rear window washer relay connector pin 2, circuit 488 (DG), and ground.</p> <p>• <b>Is voltage present?</b></p> <p>→ <b>Yes</b> REPAIR the circuit. CLEAR the DTCs. REPEAT the self-test.</p> <p>→ <b>No</b> GO to <a href="#">K12</a>.</p>
---	--

**K12 CHECK CIRCUIT 488 (DG) FOR A SHORT TO GROUND**

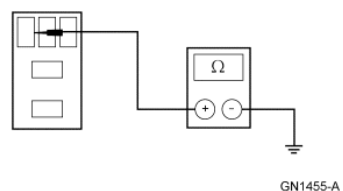





<p>1</p> 	<p>1 Measure the resistance between rear window washer relay connector pin 2, circuit 488 (DG), and ground.</p> <p>• <b>Is the resistance greater than 10,000 ohms?</b></p> <p>→ <b>Yes</b> GO to <a href="#">K13</a>.</p> <p>→ <b>No</b> REPAIR the circuit. CLEAR the DTCs. REPEAT the self-test.</p>
---	---



**K13 CHECK FOR CORRECT GEM OPERATION**

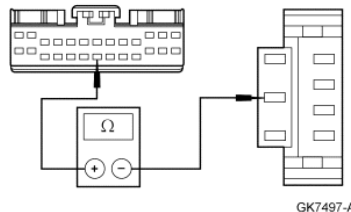

	<p>1 Disconnect all GEM connectors.</p> <p>2 Check:</p> <ul style="list-style-type: none"> <li>• for corrosion</li> <li>• for pushed out pins</li> </ul> <p>3 Connect all GEM connectors and make sure they seat correctly.</p> <p>4 Operate the system and verify the concern is still present.</p> <p>• <b>Is the concern still present?</b></p> <p>→ <b>Yes</b> INSTALL a new GEM. REFER to <a href="#">Section 419-10</a>. CLEAR the DTCs. REPEAT the self-test.</p> <p>→ <b>No</b> The system is operating correctly at this time. Concern may have been caused by a loose or corroded connector. CLEAR the DTCs. REPEAT the self-test.</p>
--	--

**PINPOINT TEST L: THE WIPERS ARE INOPERATIVE—BOTH WINDSHIELD AND REAR WINDOW**

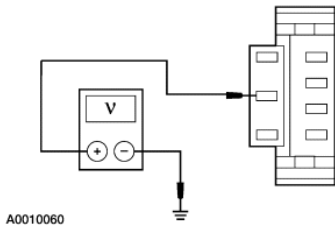
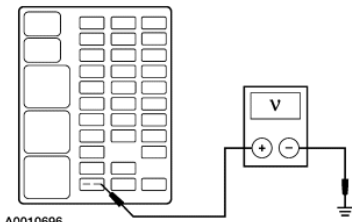
CONDITIONS	DETAILS/RESULTS/ACTIONS
L1 RETRIEVE RECORDED GENERIC ELECTRONIC MODULE (GEM) DIAGNOSTIC TROUBLE CODES (DTCs)	<p>1 Using the recorded results from the GEM front wiper self-test:</p> <p>• <b>Are any DTCs recorded?</b></p> <p>→ <b>Yes</b></p>

	<p>If DTC B1450, and B1438, GO to <a href="#">L4</a> .</p> <p>For all other DTCs, GO to <a href="#">L2</a> .</p> <p>→ <b>No</b> GO to <a href="#">L2</a> .</p>
<p><b>L2 MONITOR THE GEM PIDs</b></p>	
<p>1 </p> <p>2 </p>	<p>2 Monitor the following GEM PIDs while selecting each of the washer/wiper switch positions on the multifunction switch:</p> <ul style="list-style-type: none"> <li>• R_WP_MD</li> <li>• WASH_SW</li> <li>• WPMODE</li> </ul> <p>• <b>Do the GEM PID values agree with the multifunction switch positions?</b></p> <p>→ <b>Yes</b> GO to <a href="#">L3</a> .</p> <p>→ <b>No</b> GO to <a href="#">L4</a> .</p>
<p><b>L3 CHECK THE WINDSHIELD WIPER, REAR WINDOW WIPER, WINDSHIELD WASHER, AND REAR WINDOW WASHER OPERATION</b></p>	
<p>1 </p> <p>2 </p>	<p>2 Select the active commands as shown below. Trigger the GEM active commands to the indicated positions.</p> <ul style="list-style-type: none"> <li>• SPEED RLY to ON and OFF</li> <li>• UP RELAY to ON and OFF</li> <li>• WASH RLY (windshield) to ON and OFF</li> <li>• WIPER RLY to ON and OFF</li> <li>• WASH RLY (rear window) to ON and OFF</li> </ul> <p>• <b>Do the windshield wipers, windshield washer, rear window wiper, and rear window washer activate and deactivate correctly when the GEM active commands are triggered ON and OFF?</b></p> <p>→ <b>Yes</b> GO to <a href="#">L19</a> .</p> <p>→ <b>No</b> GO to <a href="#">L7</a> .</p>
<p><b>L4 CHECK THE MULTIFUNCTION SWITCH</b></p>	
<p>1 </p>	<p>2 Disconnect multifunction switch C230a and C230b.</p> <p>3 Carry out the multifunction switch component test. Refer to the Wiring Diagram Manual, cell 149.</p> <p>• <b>Did the multifunction switch pass the component test?</b></p> <p>→ <b>Yes</b> GO to <a href="#">L5</a> .</p> <p>→ <b>No</b> INSTALL a new multifunction switch. REFER to <a href="#">Section 211-05</a> . CLEAR the DTCs. REPEAT the self-test.</p>
<p><b>L5 CHECK CIRCUIT 682 (DB) FOR AN OPEN</b></p>	
<p>1 </p> <p>GEM C240a</p> <p>2 </p> <p>GK7497-A</p>	<p>2 Measure the resistance between multifunction switch C230a pin 993, circuit 682 (DB), harness side and GEM C240a pin 20, circuit 682 (DB), harness side.</p> <p>• <b>Is the resistance less than 5 ohms?</b></p>

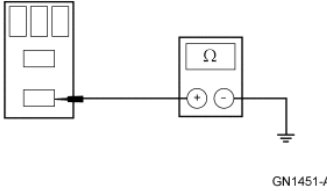
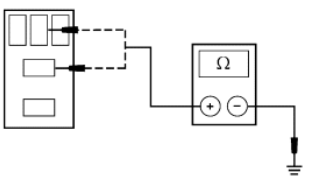
	<p>→ <b>Yes</b> GO to <a href="#">L6</a>.</p> <p>→ <b>No</b> REPAIR the circuit. CLEAR the DTCs. REPEAT the self-test.</p>
<p><b>L6 CHECK CIRCUIT 682 (DB) FOR A SHORT TO VOLTAGE</b></p>	
<p>1</p>  <p>A0010060</p>	<p>1 Measure the voltage between multifunction switch C230a pin 993, circuit 682 (DB), harness side and ground.</p> <ul style="list-style-type: none"> <li>• <b>Is any voltage indicated?</b></li> </ul> <p>→ <b>Yes</b> REPAIR the circuit. CLEAR the DTCs. REPEAT the self-test.</p> <p>→ <b>No</b> GO to <a href="#">L19</a>.</p>
<p><b>L7 CHECK FOR BLOWN CENTRAL JUNCTION BOX (CJB) FUSE 11 (30A)</b></p>	
	<p>1 Inspect CJB fuse 11 (30A).</p> <ul style="list-style-type: none"> <li>• <b>Is Fuse 11 (30A) open?</b></li> </ul> <p>→ <b>Yes</b> GO to <a href="#">L9</a>.</p> <p>→ <b>No</b> GO to <a href="#">L8</a>.</p>
<p><b>L8 CHECK CJB FUSE 11 (30A) FOR VOLTAGE</b></p>	
<p>1</p>  <p>A0010696</p>	<p>1 Measure the voltage between CJB Fuse 11 (30A) input terminal, and ground.</p> <ul style="list-style-type: none"> <li>• <b>Is any voltage indicated?</b></li> </ul> <p>→ <b>Yes</b> GO to <a href="#">L18</a>.</p> <p>→ <b>No</b> REPAIR the fuse supply circuit. CLEAR the DTCs. REPEAT the self-test.</p>
<p><b>L9 CHECK THE CJB FUSE 11 (30A) OUTPUT FOR A SHORT TO GROUND</b></p>	
	<p>1 With both windshield and rear window wiper/washer systems off, install a new CJB fuse 11 (30A).</p> <ul style="list-style-type: none"> <li>• <b>Is Fuse 11 (30A) open?</b></li> </ul> <p>→ <b>Yes</b> GO to <a href="#">L10</a>.</p> <p>→ <b>No</b> GO to <a href="#">L12</a>.</p>
<p><b>L10 CHECK THE WINDSHIELD WIPER MOTOR FOR AN INTERNAL SHORT TO GROUND</b></p>	
<p>1</p>  <p>Windshield Wiper Motor C151</p>	<p>2 With both windshield and rear window wiper/washer systems off, install a new CJB fuse 11 (30A).</p> <ul style="list-style-type: none"> <li>• <b>Is Fuse 11 (30A) open?</b></li> </ul> <p>→ <b>Yes</b> GO to <a href="#">L11</a>.</p>

	<p>→ <b>No</b> REFER to Windshield Wiper Motor Component Test in this section. CLEAR the DTCs. REPEAT the self-test.</p>
<p><b>L11 CHECK THE WIPER/WASHER SYSTEM RELAYS</b></p>	
	<p>1 Disconnect and carry out the relay component test on all of the following wiper/washer system relays. Refer to the Wiring Diagram Manual Cell 149.</p> <ul style="list-style-type: none"> <li>• windshield wiper run/park relay</li> <li>• windshield wiper high/low relay</li> <li>• windshield washer relay</li> <li>• rear window wiper relay</li> <li>• rear window washer relay</li> </ul> <p>• <b>Did all of the relays pass the component test?</b></p> <p>→ <b>Yes</b> REPAIR circuit 297 for a short to ground. CLEAR the DTCs. REPEAT the self-test.</p> <p>→ <b>No</b> INSTALL a new relay in question. CLEAR the DTCs. REPEAT the self-test.</p>
<p><b>L12 CHECK THE WINDSHIELD WIPER RUN/PARK AND HIGH/LOW RELAYS</b></p>	
	<p>1 Disconnect the windshield wiper high/low and run/park relays.</p> <p>2 Carry out the relay component test on the windshield wiper high/low and run/park relays. Refer to the Wiring Diagram Manual, cell 149.</p> <p>• <b>Did both relays pass the component test?</b></p> <p>→ <b>Yes</b> GO to <a href="#">L13</a>.</p> <p>→ <b>No</b> INSTALL a new relay in question. CLEAR the DTCs. REPEAT the self-test.</p>
<p><b>L13 CHECK CIRCUIT 63 (RD) FOR A SHORT TO GROUND</b></p>	
<p>1</p>  <p>GN1451-A</p>	<p>1 Measure the resistance between windshield wiper run/park relay connector pin 3, circuit 63 (RD), harness side and ground?</p> <p>• <b>Is the resistance greater than 10,000 ohms?</b></p> <p>→ <b>Yes</b> GO to <a href="#">L14</a>.</p> <p>→ <b>No</b> REPAIR the circuit. CLEAR the DTCs. REPEAT the self-test.</p>
<p><b>L14 ISOLATE SHORT TO GROUND AT CIRCUIT 56 (DB/OG) AND 58 (WH)</b></p>	
<p>1</p>  <p>A0010061</p>	<p>1 Measure the resistance between windshield wiper high/low relay connector pin 4, circuit 58 (WH), harness side and ground; and between windshield wiper high/low relay connector pin 5, circuit 56 (WH), harness side and ground.</p> <p>• <b>Are the resistances greater than 10,000 ohms?</b></p> <p>→ <b>Yes</b> GO to <a href="#">L16</a>.</p> <p>→ <b>No</b> GO to <a href="#">L15</a>.</p>
<p><b>L15 CHECK CIRCUITS 56 (DB/OG) AND 58 (WH) FOR A SHORT TO GROUND</b></p>	
<p>1</p>  <p>Windshield Wiper Motor C151</p> <p>2</p>	<p>2 Measure the resistance between windshield wiper high/low relay connector pin 4, circuit 58 (WH), harness side and ground; and between windshield wiper high/low relay connector pin 5, circuit 56 (WH), harness side and</p>

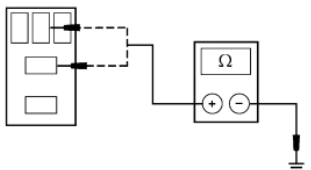

A0010061

ground.

- Are the resistances greater than 10,000 ohms?

→ **Yes**  
REFER to Windshield Wiper Motor Component Test in this section. REPAIR the circuit in question. CLEAR the DTCs. REPEAT the self-test.

→ **No**  
REPAIR the circuit in question. CLEAR the DTCs. REPEAT the self-test.

**L16 ISOLATE SHORT TO GROUND AT CIRCUIT 671 (LB)**

1



GEM C240a

2

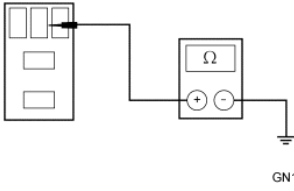

GN1454-A

2

Measure the resistance between windshield wiper run/park relay connector pin 4, circuit 671 (LB), harness side and ground.

- Is the resistance greater than 10,000 ohms?

→ **Yes**  
GO to [L19](#).

→ **No**  
GO to [L17](#).

**L17 CHECK CIRCUIT 671 (LB) FOR SHORT TO GROUND**

1



Windshield Wiper Motor C151

2

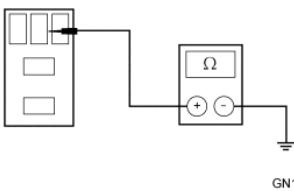

GN1454-A

2

Measure the resistance between windshield wiper run/park relay connector pin 4, circuit 671 (LB), harness side and ground.

- Is the resistance greater than 10,000 ohms?

→ **Yes**  
REFER to Windshield Wiper Motor Component Test in this section. REPAIR the circuit in question. CLEAR the DTCs. REPEAT the self-test.

→ **No**  
REPAIR the circuit. CLEAR the DTCs. REPEAT the self-test.

**L18 CHECK CIRCUIT 297 (BK/LG) FOR AN OPEN**

2



3

1

Disconnect the windshield wiper run/park relay.

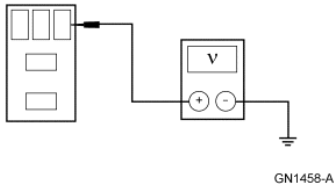

3 Measure the voltage between windshield wiper run/park relay connector pin 1, circuit 297 (BK/LG), harness side and ground.

- Is the voltage greater than 10 volts?

→ **Yes**  
GO to [L19](#).

→ **No**  
REPAIR the circuit. CLEAR the DTCs. REPEAT the self-test.

**L19 CHECK FOR CORRECT GEM OPERATION**





- 1 Disconnect all GEM connectors.
- 2 Check:
  - for corrosion
  - for pushed out pins
- 3 Connect all GEM connectors and make sure they seat correctly.
- 4 Operate the system and verify the concern is still present.

- Is the concern still present?

→ **Yes**  
INSTALL a new GEM. REFER to [Section 419-10](#). CLEAR the DTCs. REPEAT the self-test.

→ **No**  
The system is operating correctly at this time. Concern may have been caused by a loose or corroded connector. CLEAR the DTCs. REPEAT the self-test.

**PINPOINT TEST M: THE WASH AND WIPE FUNCTION DOES NOT OPERATE—BOTH WINDSHIELD AND REAR WINDOW**

CONDITIONS	DETAILS/RESULTS/ACTIONS
<p><b>M1 MONITOR THE GENERIC ELECTRONIC MODULE (GEM) PID WPMODE</b></p>	
<p>1 </p> <p>2 </p>	<p>2 Monitor GEM PIDs R_WP_MD, WASH_SW, and WPMODE while selecting each of the multifunction switch windshield and rear window wiper positions and depressing the windshield and rear window washer switches.</p> <ul style="list-style-type: none"> <li>• Do the GEM PID values agree with the multifunction switch positions?</li> </ul> <p>→ <b>Yes</b> GO to <a href="#">M2</a>.</p> <p>→ <b>No</b> GO to <a href="#">M10</a>.</p>
<p><b>M2 CHECK THE WINDSHIELD AND REAR WINDOW WIPER/WASHER OPERATION</b></p>	
<p>1 </p>	<p>1 Select GEM active command WASH RLY. Trigger GEM active command WASH RLY to the ON and OFF positions.</p> <ul style="list-style-type: none"> <li>• Does the wiper/washer system operate correctly when WASH RLY is triggered ON and OFF?</li> </ul> <p>→ <b>Yes</b> GO to <a href="#">M11</a>.</p> <p>→ <b>No</b> GO to <a href="#">M3</a>.</p>
<p><b>M3 CHECK BATTERY JUNCTION BOX (BJB) FUSE 13 (10A) FOR VOLTAGE</b></p>	
<p>1 </p> <p>BJB Fuse 13 (10A)</p> <p>2</p>	

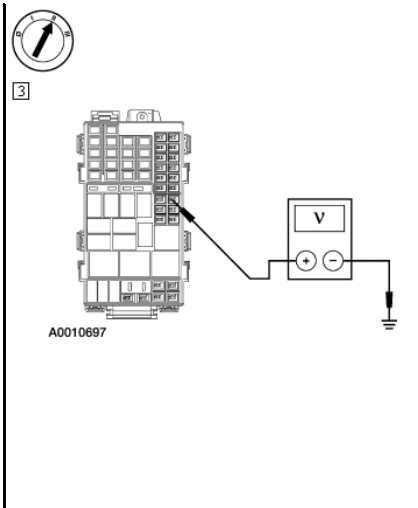

3 Measure the voltage between BJB Fuse 13 (10A) input terminal and ground.

- Is the voltage greater than 10 volts?

→ Yes  
RECONNECT BJB Fuse 13 (10A). GO to [M4](#).

→ No  
REPAIR the BJB as necessary. CLEAR the DTCs. REPEAT the self-test.

**M4 CHECK CIRCUIT 950 (WH/BK) FOR AN OPEN**

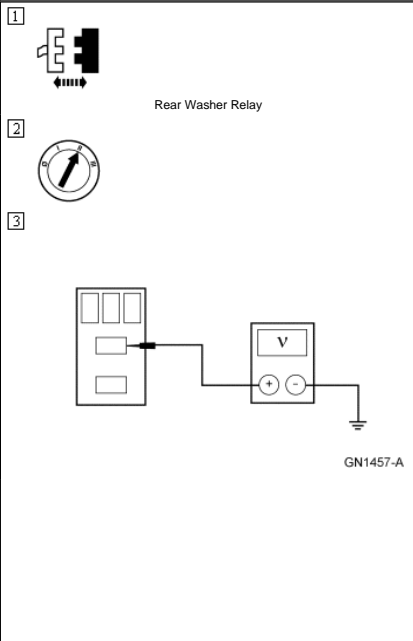

3 Measure the voltage between rear window washer relay connector pin 5, circuit 297 (BK/LG), harness side and ground.

- Is the voltage greater than 10 volts?

→ Yes  
GO to [M5](#).

→ No  
REPAIR the circuit. CLEAR the DTCs. REPEAT the self-test.

**M5 CHECK CIRCUIT 57 (BK) FOR AN OPEN**

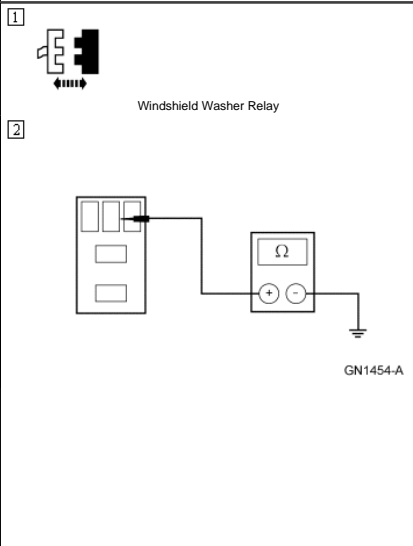

2 Measure the resistance between windshield washer relay connector pin 4, circuit 57 (BK), harness side and ground; and between rear window washer relay connector pin 4, circuit 57 (BK), harness side and ground.

- Is the resistance less than 5 ohms?

→ Yes  
GO to [M6](#).

→ No  
REPAIR the circuit. CLEAR the DTCs. REPEAT the self-test.

**M6 CHECK THE WASHER PUMP RELAYS**

<p>1</p> 	<p>2 Carry out the relay component test on both the windshield and rear window washer relays. Refer to the Wiring Diagram Manual, cell 149.</p> <ul style="list-style-type: none"> <li>• Did both relays pass the component test?</li> </ul> <p>→ <b>Yes</b> GO to <a href="#">M7</a>.</p> <p>→ <b>No</b> INSTALL a new relay. CLEAR the DTCs. REPEAT the self-test.</p>
--	--

**M7 CHECK CIRCUITS 946 (PK/LG) AND 941 (BK/WH) FOR AN OPEN**

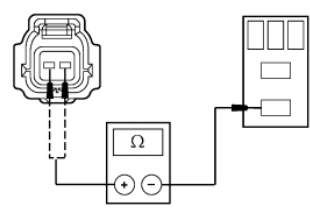
<p>1</p>  <p>Washer Pump Motor C1030</p> <p>2</p>  <p>A0010062</p>	<p>2 Measure the resistance between windshield washer relay connector pin 3, circuit 946 (PK/LG), harness side and washer pump motor C1030, circuit 946 (PK/LG), harness side; and between rear window washer relay connector pin 3, circuit 941 (BK/WH), harness side and washer pump motor C1030, circuit 941 (BK/WH), harness side.</p> <ul style="list-style-type: none"> <li>• Are the resistances less than 5 ohms?</li> </ul> <p>→ <b>Yes</b> GO to <a href="#">M8</a>.</p> <p>→ <b>No</b> REPAIR the circuit in question. CLEAR the DTCs. REPEAT the self-test.</p>
--	---

**M8 CHECK CIRCUITS 946 (PK/LG) AND 941 (BK/WH) FOR A SHORT TO VOLTAGE**

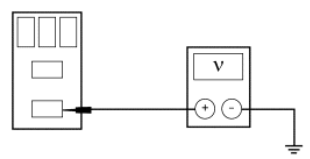
<p>1</p>  <p>GN1456-A</p>	<p>1 Measure the voltage between windshield washer relay connector pin 3, circuit 946 (PK/LG), harness side and ground; and between rear window washer relay connector pin 3, circuit 941 (BK/WH), harness side and ground.</p> <ul style="list-style-type: none"> <li>• Is voltage present?</li> </ul> <p>→ <b>Yes</b> REPAIR the circuit in question. CLEAR the DTCs. REPEAT the self-test.</p> <p>→ <b>No</b> GO to <a href="#">M9</a>.</p>
--	--

**M9 CHECK CIRCUITS 946 (PK/LG) AND 941 (BK/WH) FOR A SHORT TO GROUND**

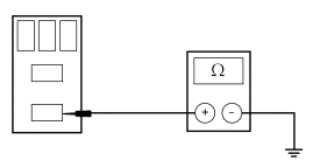
<p>1</p>  <p>GN1451-A</p>	<p>1 Measure the resistance between windshield washer relay connector pin 3, circuit 946 (PK/LG), harness side and ground; and between rear window washer relay connector pin 3, circuit 941 (BK/WH), harness side and ground.</p> <ul style="list-style-type: none"> <li>• Are the resistances greater than 10,000 ohms?</li> </ul> <p>→ <b>Yes</b> INSTALL a new washer pump. REFER to <a href="#">Washer Pump and Reservoir</a> in this Section. CLEAR the DTCs. REPEAT the self-test.</p>
--	---

	→ <b>No</b> REPAIR the circuit in question. CLEAR the DTCs. REPEAT the self-test.
<b>M10 CHECK THE MULTIFUNCTION SWITCH</b>	
	<ol style="list-style-type: none"> <li>1</li> <li>2 Disconnect multifunction switch C230a and C230b.</li> <li>3 Carry out the multifunction switch component test. Refer to the Wiring Diagram Manual Cell 149.</li> </ol> <ul style="list-style-type: none"> <li>• <b>Did the multifunction switch pass the component test?</b></li> </ul> <p>→ <b>Yes</b> GO to <a href="#">M11</a>.</p> <p>→ <b>No</b> INSTALL a new multifunction switch. REFER to <a href="#">Section 211-05</a>. CLEAR the DTCs. REPEAT the self-test.</p>
<b>M11 CHECK FOR CORRECT GEM OPERATION</b>	
	<ol style="list-style-type: none"> <li>1 Disconnect all GEM connectors.</li> <li>2 Check: <ul style="list-style-type: none"> <li>• for corrosion</li> <li>• for pushed out pins</li> </ul> </li> <li>3 Connect all GEM connectors and make sure they seat correctly.</li> <li>4 Operate the system and verify the concern is still present.</li> </ol> <ul style="list-style-type: none"> <li>• <b>Is the concern still present?</b></li> </ul> <p>→ <b>Yes</b> INSTALL a new GEM. REFER to <a href="#">Section 419-10</a>. CLEAR the DTCs. REPEAT the self-test.</p> <p>→ <b>No</b> The system is operating correctly at this time. Concern may have been caused by a loose or corroded connector. CLEAR the DTCs. REPEAT the self-test.</p>

#### Component Test — Windshield Wiper Motor

**⚠ CAUTION:** Do not handle the windshield wiper motor abusively when diagnosing the wiper operations. Failure to follow this caution may result in damage to the motor magnets and will make the windshield wiper inoperative. Rough handling of new replacement windshield wiper motors may also damage the motor magnets.

Use alternator, regulator, battery and starter tester (ARBST) to test the wiper motor on the vehicle.

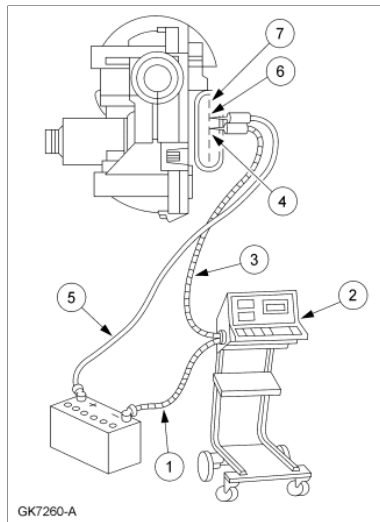

To test the wiper motor, disconnect the windshield wiper mounting arm and pivot shaft from the windshield wiper motor. Refer to [Wiper Mounting Arm and Pivot Shaft](#).

Disconnect the wiper motor. Connect the (1) green lead from the (2) ARBST to the battery negative (-) post. Connect the (3) red lead from the ARBST to the wiper motor (4) common brush terminal (terminal 3).

Test the low speed mode by connecting a (5) cable from the battery positive (+) post to the (6) low speed brush terminal (terminal 4) and measure the current draw. If the current draw is greater than 3.5 amperes, install a new windshield wiper motor. Refer to [Windshield Wiper Motor](#).

Test the high speed mode by connecting a cable from the battery positive (+) post to the (7) high speed brush terminal (terminal 5) and measure the current draw. If the current draw is greater than 5.5 amperes, install a new windshield wiper motor. Refer to [Windshield Wiper Motor](#).

